



CONSTRUCTION  
INDUSTRY COUNCIL  
建造業議會

# Reference Materials on Seismic Detailing for Concrete Buildings in Hong Kong



# Reference Materials on Seismic Detailing for Concrete Buildings in Hong Kong

## Author

Dr SU Kai Leung, Ray

The University of Hong Kong

## Disclaimer

Whilst reasonable efforts have been made to ensure the accuracy of the information contained in this publication, the CIC nevertheless would encourage readers to seek appropriate independent advice from their professional advisers where possible and readers should not treat or rely on this publication as a substitute for such professional advice for taking any relevant actions.

## Enquiries

Any enquiries may be made to the CIC Secretariat at: CIC Headquarters

38/F, COS Centre, 56 Tsun Yip Street, Kwun Tong, Kowloon, Hong Kong

Tel: (852) 2100 9000

Fax: (852) 2100 9090

Email: [enquiry@cic.hk](mailto:enquiry@cic.hk)

Website: [www.cic.hk](http://www.cic.hk)

© 2019 Construction Industry Council

## Foreword

The Construction Industry Council (CIC) was formed on 1st February 2007 in accordance with the Construction Industry Council Ordinance (Cap. 587) in Hong Kong. The main functions of the CIC are to forge consensus on long-term strategic issues, to convey the industry's needs and aspirations to the Government and to provide a communication channel through which the Government can solicit advice on all construction-related matters.

The CIC Research Fund was established in September 2012 in order to enhance the efficiency and competitiveness of the local construction industry. The CIC Research Fund encourages research and development activities as well as applications of innovative techniques that directly meet the needs of the industry. Moreover, it also promotes the establishment of standards and good practice for the construction industry, now and into the future.

This Technical Guide aims to promote knowledge in relation to practical and optimal seismic reinforced concrete (RC) to the Hong Kong construction industry with a strong emphasis on safety, effectiveness, efficiency and buildability. This Guide first quantifies the seismic deformability demands of typical RC building systems such as walls, frames and dual systems. Appropriate proportioning and seismic detailing requirements with reference to the local code of practice are then recommended for each system so as to ensure that seismic deformation capacity is higher than the expected demands of such RC components as walls, coupling beams, floor beams and columns. Optimal seismic detailing can be achieved by making savings on unnecessary construction materials and processes.

The main features of this Guide include:

1. the seismic drift predictions, expressed in terms of drift ratio and beam chord rotation, with return periods of 475 and 2475 years, of typical RC building components including walls, frames and dual systems;
2. the specification of both inter-storey and distortional inter-storey drift ratio demands, as the latter is applicable to control over the seismic deformation of buildings with transfer structures;
3. recommendations for the prescriptive seismic detailing requirements for common types of RC buildings in HK;
4. the provision of ultimate drift ratio prediction formulas for beams, columns and walls validated with test data, from which engineers may estimate member sizes and determine loading and detailing requirements to suit performance criteria prescribed in the performance-based seismic design; and
5. the recommendation of simplified beam-column joint details.

## Acknowledgements

The author would like to thank the following practitioners and academics for their assistance in the preparation and review of this Guide.

Ir Dr Goman Ho	Arup
Ir Dr Don Ho	Arup
Ir Dr Kent Hou	Arup
Richard Lee	Yau Lee Construction Company Limited
Dr Chien-Liang Lee	Xiamen University of Technology
Qifang Liu	The University of Hong Kong
Daniel Looi	The University of Hong Kong
Dr Zuanfeng Pan	Tongji University
Dr Hing-Ho Tsang	Swinburne University of Technology

# Table of Contents

1	INTRODUCTION.....	1
1.1	Background.....	1
1.2	Scope.....	1
1.3	Limitations.....	2
1.4	Way forward.....	2
1.5	Terms and definitions.....	2
1.6	Symbols.....	4
1.7	Concrete material.....	6
1.8	Evaluation of seismic deformation demands.....	6
1.9	References.....	18
2	WALL SYSTEMS.....	21
2.1	Scope.....	21
2.2	Detailing considerations.....	21
2.3	Structural walls.....	23
2.4	Coupling beams.....	30
2.5	RC columns.....	32
2.6	Frame beams.....	34
2.7	RC beam-column joints.....	36
2.8	References.....	38
3	DUAL SYSTEMS.....	40
3.1	Scope.....	40
3.2	Detailing considerations.....	40
3.3	Structural walls.....	43
3.4	Ductile coupling beams.....	47
3.5	Ductile columns.....	48
3.6	Ductile frame beams.....	53
3.7	RC beam-column joints.....	56
3.8	Drift ratio design formulas for rectangular walls.....	58
3.9	References.....	59
4	FRAME SYSTEMS.....	61
4.1	Scope.....	61
4.2	Detailing considerations.....	61
4.3	Ductile columns.....	63
4.4	Ductile frame beams.....	68
4.5	Beam-column joints.....	71
4.6	Drift ratio design formulas for columns and beams.....	74
4.7	References.....	77

# 1 INTRODUCTION

## 1.1 Background

The main goals of earthquake-resistant design are to attain a structure with sufficient strength, stiffness and deformability to prevent collapse under a rare earthquake, and to remain operational after an occasional earthquake and undamaged during a frequent earthquake. Hong Kong is located in a region of low-to-moderate seismicity. In general, local reinforced concrete (RC) building structures – even those lacking seismic design and detailing – are able to resist frequent earthquakes without incurring damage. During an occasional earthquake, almost all RC buildings respond within an elastic or near elastic range, with the exception of certain flexible low-rise RC frames which may respond inelastically and experience repairable damage to structural and non-structural components.

When tall buildings in Hong Kong are subjected to rare earthquake loads, the drift ratio demand is often limited due to the saturation of displacement demands within the long period range of the design spectra. These buildings typically respond in an elastic or near elastic range and, as such, ductile detailing and design for most of the structural components (except those adjoining transfer structures) may not be required. The primary seismic design objective of tall buildings is to provide sufficient strength to avoid the kind of premature brittle failure associated with the shear or compressive failure that occurs during a rare earthquake situation.

For low or medium rise RC buildings subjected to rare earthquake loads, the deformation demand is generally much higher. However, it is both impractical and uneconomical to design all such buildings to respond in the elastic range. Earthquake-resistant design is achieved by allowing yielding to take place in certain structural members. Appropriate proportioning and detailing of such structural members and joints are required if these buildings are to resist the force and deformation demands inflicted by the combined effects of gravity and seismic loads.

When comparing local seismic demands with those of historical destructive earthquakes, the seismic displacement and ductility demands encountered in Hong Kong are expected to be relatively small. The high ductility RC detailing commonly adopted in such high seismicity regions as New Zealand, the Western US and Japan are not appropriate for Hong Kong, with its low-to-moderate seismicity. Furthermore, tall buildings with heights exceeding 100 m are widely constructed in Hong Kong. The unique structural systems and seismic responses of buildings in Hong Kong warrant the development of specialised seismic detailing to suit local conditions.

## 1.2 Scope

The objective of this Guide is to evaluate and propose the seismic detailing requirements for typical monolithically cast-in-situ and equivalent monolithic precast RC buildings with a building height not exceeding 300 m in Hong Kong. The precast RC structural system referred to in this Guide should have a

strength and deformability capacity equivalent to that provided by a comparable monolithic RC structure. Covered herein are detailing provisions for:

1. Low-to-high rise buildings with wall systems
2. Low-to-high rise buildings with dual systems
3. Low-to-medium rise buildings with frame systems

The tables and figures provided summarise the required provisions for the members considered. Each table contains code-prescribed detailing requirements with cross-references to the appropriate clause numbers of the Code of Practice of Structural Use of Concrete (BD 2013), if any. Additional provisions recommended for achieving the intended seismic deformation capacity are highlighted with bold fonts.

### **1.3 Limitations**

The detailing provisions provided are only applicable to the design of typical buildings in Hong Kong, with deformation demands not exceeding the prescribed drift ratio limits listed in **Table 1.6** and non-ductile actions being duly undertaken so as to avoid premature failure (such as by way of the shear or crushing failure of concrete). The detailing provisions provided in this Guide include some nominal effects concerning the twisting of building and additional deformation associated with transfer structures. However, increased seismic deformation demands resulting from significant torsional effects, complicated transfer systems and topographic effects should be assessed individually. Non-linear time history analysis is recommended for estimating the actual deformation demands of these buildings.

### **1.4 Way forward**

The Buildings Departments (BD) is concurrently engaging a consultant to develop a new seismic design code to provide seismic-resistant building design standards and enhance the structural safety of buildings in the event of earthquakes in Hong Kong. During the course of the research project, the draft guidelines have been sent to relevant parties including BD's consultants, relevant contractor and academia for comments. The draft guide has already incorporated their comments. As the way forward, the guide could be sent to BD for their consideration in incorporation into its new seismic design code

### **1.5 Terms and definitions**

The following terms are used in this Guide with the following meanings:

#### **axial load ratio**

axial compressive force divided by the section area and the expected cylinder concrete strength

#### **beam chord rotation**

rotation between the chord connecting the member end to the point of contraflexure and the tangent at the member end (see **Fig. 1.1**)

**distortional inter-storey drift ratio**

shear deformation component of the inter-storey drift ratio

**dual system**

structural system in which support for vertical loads is mainly provided by a spatial frame and resistance to lateral loads is contributed to in part by the frame system and in part by structural walls (coupled, uncoupled or core)

**frame system**

structural system in which both vertical and lateral loads are mainly resisted by spatial frames whose shear resistance at the building base exceeds 60% of the total shear resistance of the whole structural system

**high rise building**

building with a height greater than 50 m and not exceeding 300 m

**inter-storey drift ratio**

relative horizontal displacement of two adjacent floors divided by the floor height

**low-to-medium rise building**

building with a height not exceeding 50 m

**shear span**

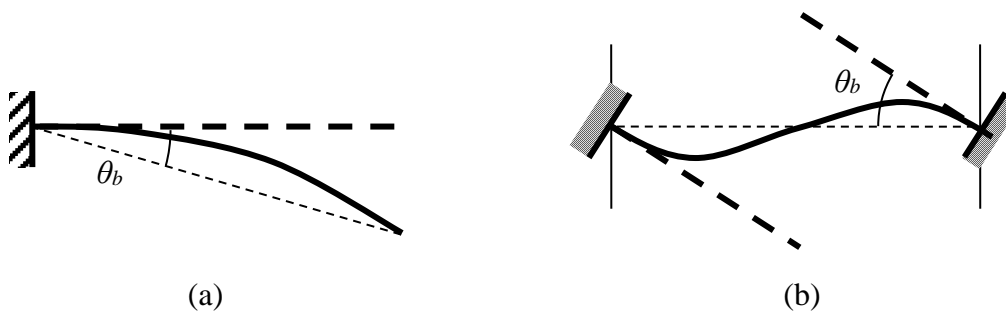
member's end moment divided by end shear along the same considered plane

**shear span-to-depth ratio**

shear span divided by the depth of the section along the shear considered

**wall system**

structural system in which both vertical and lateral loads are mainly resisted by vertical structural walls (coupled, uncoupled or core), whose shear resistance at the building base exceeds 60% of the total shear resistance of the whole structural system



**Figure 1.1** Beam chord rotation (a) cantilever example and (b) frame example



## 1.6 Symbols

The following symbols are used in this Guide with the following meanings:

$A_g$	Sectional area
$A_v$	Shear area of a section
$b, b_b$	Beam width
$b_o, h_o$	Dimensions of the confined core to the centre-line of the link in a beam
$b_i$	Centre-line spacing along the section's perimeter of the longitudinal bars which are engaged by a link corner or a cross-tie
$b_j$	Lateral dimension of joint
$b_w$	Thickness of wall
$d$	Effective depth of section
$d_i$	Depth of the soil layer
$E_c$	Young's modulus of concrete
$f'_{c,k}$	Characteristic cylinder strength of concrete
$f'_{c,m}$	Mean cylinder strength of concrete
$f_{cu,k}$	Characteristic cube strength of concrete
$f_{cu,m}$	Mean cube strength of concrete
$f_{yw,k}$	Characteristic yield strength of side bar
$f_{yh,k}$	Characteristic yield strength of horizontal reinforcement
$f_{yt,m}$	Mean yield strength of transverse (or hoop) reinforcement
$f_{yl}$	Service stress in longitudinal reinforcement
$f_{y1,m}$	Mean yield strength of longitudinal (or vertical) reinforcement
$f_{y11,m}$	Mean yield strength of longitudinal tensile reinforcement
$f_{y12,m}$	Mean yield strength of longitudinal compression reinforcement
$f_{yh,m}$	Mean yield strength of horizontal reinforcement
$f_{y1w,m}$	Mean yield strength of longitudinal tensile reinforcement in web
$f_{yv,m}$	Mean yield strength of shear reinforcement
$F_u$	Peak loading capacity
$G_c$	Shear modulus of concrete
$h_c, b_c$	Sectional dimensions of a column
$h$	Depth of beam
$h_i$	Floor height of the $i^{th}$ floor
$h_w$	Depth of wall
$H$	Storey height
$H_b$	Height of building
$l_{cr}$	Extent of critical zone
$I_g$	Sectional second moment of area
$J$	Polar moment of area
$k_y$	Initial cracked effective stiffness
$k_o$	Intact stiffness
$k_u$	Lower-bound effective stiffness
$l_o$	Length of tension lap
$L_v$	Shear span
$M$	End moment
$M_b$	End moment of coupling beam
$N_{cr}$	Axial compression ratio
$N_{ult}$	Factored gravity axial load
$N_{work}$	Unfactored axial load

$RSA$	Response spectral acceleration
$RSA_{max}$	Maximum response spectral acceleration
$RSD$	Response spectral displacement
$s_b$	Spacing of side bars
$s_h$	Spacing of horizontal reinforcement
$s_t$	Spacing of transverse (or hoop) reinforcement
$s_{t1}, s_{t2}$ and $s_{t3}$	Dimensions of confined zone
$s_v$	Spacing of shear reinforcement
$s_{vj}$	Spacing of the vertical joint shear reinforcement
$s_\phi$	Clear spacing between tension reinforcement
$T$	Structural period
$T_i$	Site initial natural period
$T_1$	First corner period
$T_2$	Second corner period
$T_{eff}$	Effective structural period
$T_o$	Structural period using cracked stiffness
$v$	shear stress capacity of a section
$V$	End shear
$V_b$	End shear of coupling beam
$V_i$	Initial shear wave velocity of the soil layer
$x_i$	$i^{th}$ floor lateral displacement
$\beta$	Period shift factor
$\beta_b$	Redistribution ratio
$\Delta_{eff}$	Effective displacement
$\Delta_y$	Yield deformation
$\Delta_u$	Ultimate deformation
$\Delta_1, \Delta_2$	Minimum and maximum lateral deformations
$\mu_d$	Displacement ductility capacity
$\rho_l$	Area ratio of longitudinal reinforcement
$\rho_h$	Area ratio of horizontal reinforcement
$\rho_t$	Area ratio of transverse reinforcement
$\rho_v$	Area ratio of shear reinforcement
$\rho_{l1}$	Area ratio of longitudinal tensile reinforcement
$\rho_{21}$	Area ratio of longitudinal compression reinforcement
$\rho_{lw}$	Area ratio of longitudinal tensile reinforcement in web
$\rho_{t,vol}$	volumatic ratio of hoop reinforcement
$\phi$	Diameter of the longitudinal bar
$\phi_{l,max}$	Maximum diameter of longitudinal reinforcement
$\phi_{l,min}$	Minimum diameter of longitudinal reinforcement
$\phi_h$	Diameter of horizontal reinforcement
$\phi_t$	Diameter of transverse reinforcement
$\theta$	Inter-storey drift ratio
$\theta_b$	Beam chord rotation
$\theta_d$	Distortional inter-storey drift ratio
$\theta_f$	Local floor rotation
$\omega_1$	Total reinforcement ratio of tension and web longitudinal reinforcement
$\omega_2$	Total reinforcement ratio of compression longitudinal reinforcement
$\omega_v$	Mechanical ratio of vertical reinforcement
$\omega_h$	Mechanical ratio of horizontal reinforcement
$\omega_t$	Mechanical ratio of hoop reinforcement

## 1.7 Concrete material

The design concrete grades considered in this Guide are generally based on C30 to C60 for cast-in-situ RC buildings and C30 to C50 for the equivalent monolithic precast RC buildings. High strength concrete with a concrete grade above C60 may be applied when the member considered remains elastic under rare earthquake actions. The requirements on all confinement, links, ties and minimal reinforcement should be increased by  $f_{cu,k}/60$ .

## 1.8 Evaluation of seismic deformation demands

The seismic deformation demands of an RC building primarily depend on the site conditions, the return period of the earthquake, the ground motions and the structural system considered. In order to accurately estimate seismic deformation demands, computer models offering appropriate simulation techniques should be adopted. In the following sections, the factors affecting seismic deformation demands will be presented.

### 1.8.1 Earthquake response spectra

The dynamic characteristics of an earthquake can be conveniently quantified by way of an earthquake response spectrum. In this Guide, rare earthquake response spectra (with a return period of 2475 years, i.e. a 2% probability of exceedance in 50 years) and occasional earthquake response spectra (with a return period of 475 years, i.e. a 10% probability of exceedance in 50 years) developed based on typical site conditions in Hong Kong are employed for the evaluation of the seismic response of buildings.

The site initial natural period  $T_i$  can be estimated based on geophysical or geotechnical measurements with the use of Equation (1.1) where  $d_i$  (in m) is the thickness of the individual soil layer and  $V_i$  (in m/s) is the initial shear wave velocity.

$$T_i = \sum_{i=1}^n \frac{4d_i}{V_i} \quad (1.1)$$

The response spectra are separated into four types according to  $T_i$ . The site classification is shown in **Table 1.1** in which Site 0 is a rock site and Sites 1, 2 and 3 are soil sites with increasing soil depths and decreasing soil stiffnesses.

**Table 1.1** Site classification

Site Period	Site Classification	
$T_i \leq 0.15$ s	Site 0	Rock Site
$0.15 < T_i \leq 0.3$ s	Site 1	Soil Site
$0.3 < T_i \leq 0.7$ s	Site 2	
$0.7 < T_i \leq 5$ s	Site 3	

The four types of rare earthquake and occasional earthquake response spectra, with a 5% damping ratio for Hong Kong in the ADRS (acceleration-displacement response spectra) and RSA (response spectrum acceleration) formats, are presented in **Figs. 1.2** and **1.3** respectively. The corner periods of the rare earthquake and occasional earthquake response spectra are summarised in **Tables 1.2** and **1.3**

respectively. The spectral displacements of rock sites and soil sites can be obtained from Equations (1.2) and (1.3) respectively. For details on the construction of the design response spectra, it is recommended that the reader review the works of Su et al. (2015a).

$$\left. \begin{aligned} T \leq T_1 : & \quad RSD_T(\text{mm}) = RSA_{\max} \times (T/2\pi)^2 \times 9810 \\ T_1 < T \leq T_2 : & \quad RSD_T(\text{mm}) = RSA_{\max} \times TT_1 / (2\pi)^2 \times 9810 \\ T_2 < T \leq 5.0\text{s} : & \quad RSD_T(\text{mm}) = RSA_{\max} \times (T/2\pi)^2 \times 9810 [1 + 0.44 \times (T - 1)] \end{aligned} \right\} \quad (1.2)$$

$$\left. \begin{aligned} T \leq T_1 : & \quad RSD_T(\text{mm}) = RSA_{\max} \times (T/2\pi)^2 \times 9810 \\ T_1 < T \leq T_2 : & \quad RSD_T(\text{mm}) = RSA_{\max} \times TT_1 / (2\pi)^2 \times 9810 \\ T_2 < T \leq 5.0\text{s} : & \quad RSD_T(\text{mm}) = RSA_{\max} \times T_1 T_2 / (2\pi)^2 \times 9810 \end{aligned} \right\} \quad (1.3)$$

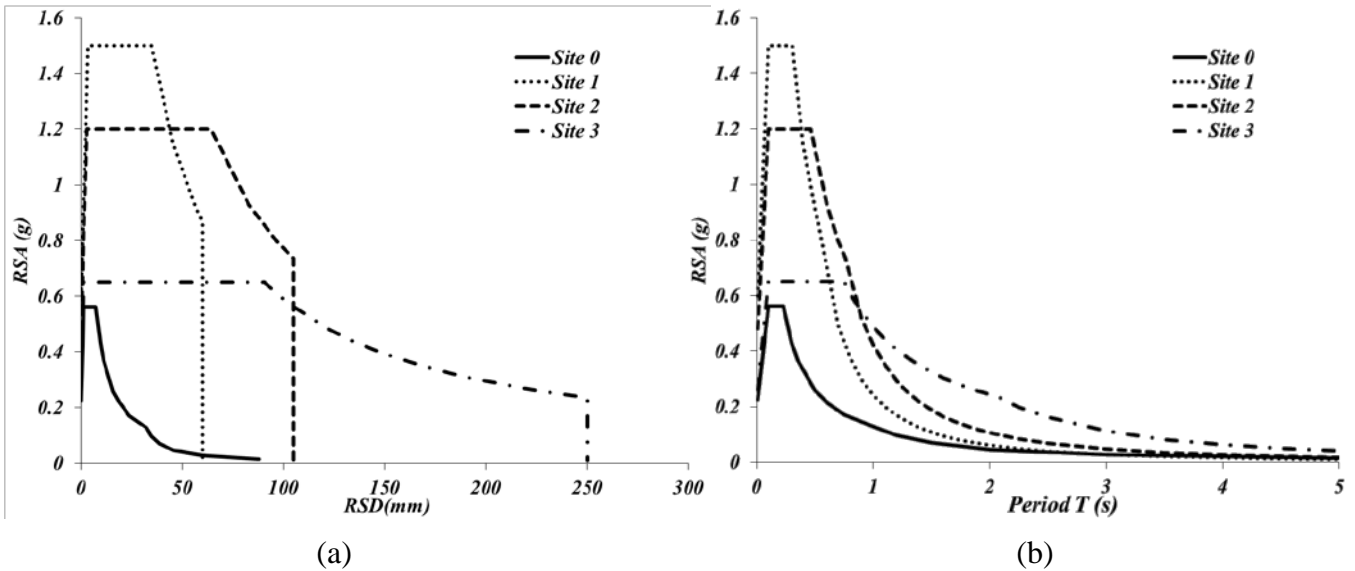
As shown in **Figs. 1.2** and **1.3**, the seismic demands of occasional earthquakes are around 50 to 60% of those of rare earthquakes, while the demands of rock sites are in general about 20 to 40% of those of soil sites.

**Table 1.2**  $RSA_{\max}$  and corner periods ( $T_1$  and  $T_2$ ) for the rare earthquake response spectra

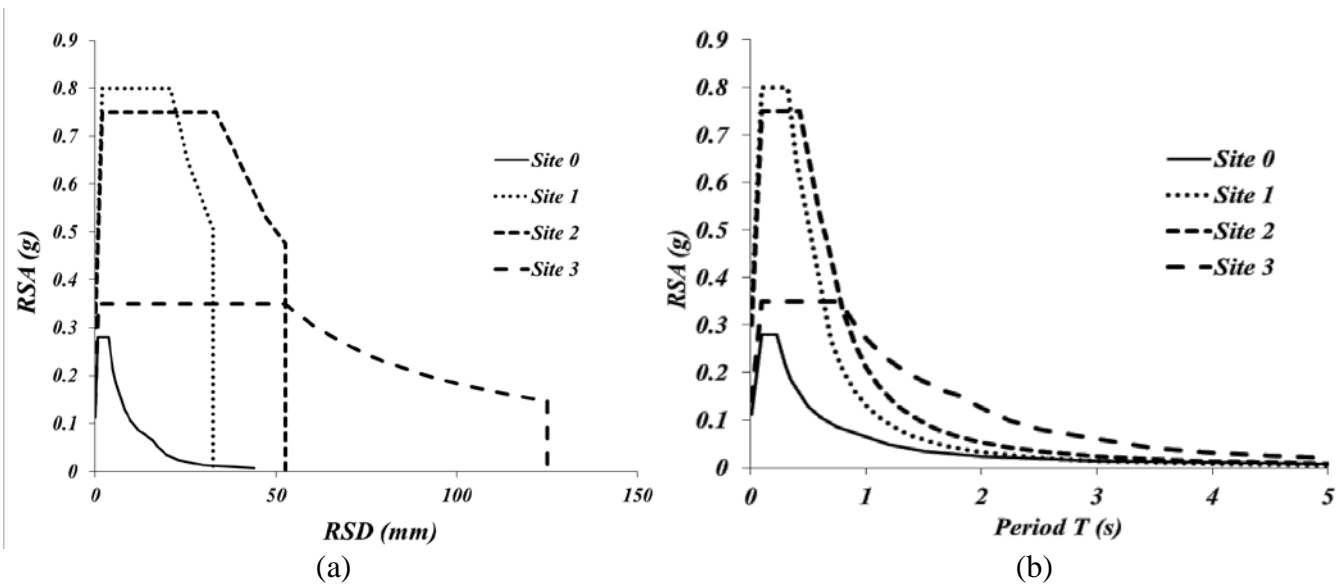
Site types	$RSA_{\max}$ (g)	$T_1$ (s)	$T_2$ (s)
Site 0	0.56	0.23	1.00
Site 1	1.50	0.30	0.55
Site 2	1.20	0.45	0.80
Site 3	0.65	0.75	2.00

**Table 1.3**  $RSA_{\max}$  and corner periods ( $T_1$  and  $T_2$ ) for the occasional earthquake response spectra

Site types	$RSA_{\max}$ (g)	$T_1$ (s)	$T_2$ (s)
Site 0	0.28	0.23	1.00
Site 1	0.80	0.32	0.51
Site 2	0.75	0.42	0.67
Site 3	0.35	0.78	1.85



**Figure 1.2** Four types of rare earthquake response spectra for Hong Kong presented in (a) ADRS format and (b) RSA format



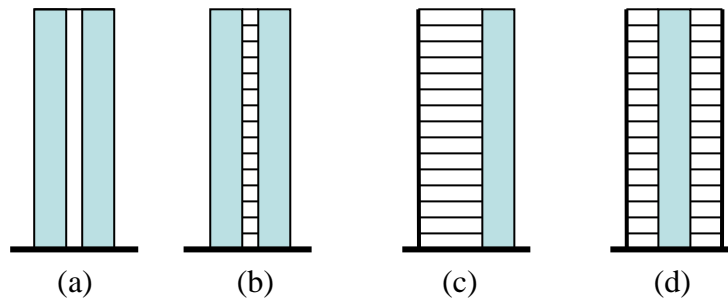
**Figure 1.3** Four types of occasional earthquake response spectra for Hong Kong presented in (a) ADRS format and (b) RSA format

### 1.8.2 Structural system

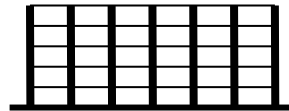
The seismic deformation demands of three types of RC structural systems as shown in **Figs. 1.4 to 1.6** with various building heights  $H_b$  have been investigated in this Guide.

1. Low-to-high rise buildings with wall systems ( $H_b \leq 300$  m)
2. Low-to-high rise buildings with dual systems ( $H_b \leq 300$  m)
3. Low-to-medium rise buildings with frame systems ( $H_b \leq 50$  m)

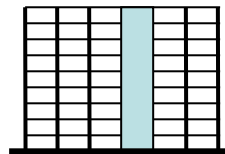
These represent the most common building formats in Hong Kong.



**Figure 1.4** Wall systems (a) uncoupled, (b) coupled, (c) wall-frame and (d) core wall with frame

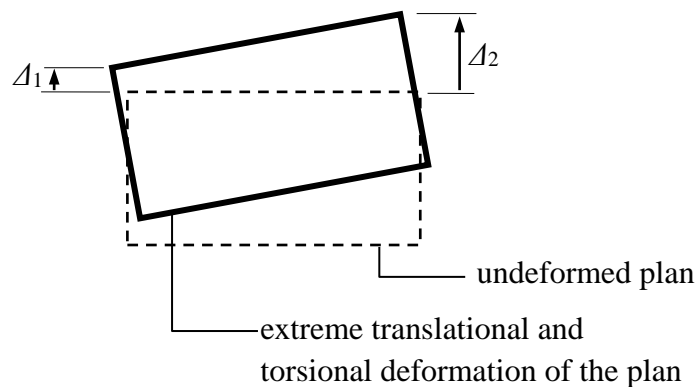


**Figure 1.5** Frame system with a strong-column and weak-beam arrangement



**Figure 1.6** Dual system

Torsional irregularity, in this Guide, is defined as the maximum to minimum lateral floor deformation ratio  $\Delta_2/\Delta_1$  as illustrated in **Fig. 1.7**. The maximum value of  $\Delta_2/\Delta_1$  considered in this Guide is 2.3.



**Figure 1.7** Extreme torsional plan rotation

### 1.8.3 Structural modelling

Three-dimensional building models are generally required for all analyses and evaluations, in order to represent the spatial distribution of the mass and stiffness of a structure to an extent that is adequate for the calculation of the significant features of the building's dynamic response. Structural models shall incorporate realistic estimates of stiffness and damping, considering the anticipated levels of excitation

and damage. In addition to the designated elements and components of the lateral force resisting system, all other elements that in combination significantly contribute to or affect the total or local stiffness of the building shall be included in the mathematical model. Expected material properties shall be used throughout. The stiffness properties of reinforced concrete shall consider the effects of cracking on stiffness. For further reference on local concrete material properties, including the Young's modulus and expected cube strength, interested readers can refer to Su (2015a).

#### 1.8.4 Effective stiffness

In order to accurately predict the seismic response and deformation demands of buildings, realistic member stiffnesses shall be used in structural models with a consideration of the anticipated level of excitation and damage. The effective stiffness approaches most widely used in various international design codes and standards (ASCE, 2007; CSA, 2004; PEER/ATC-72-1, 2010; LATBSDC, 2011; ACI 318, 2014; BSI, 2005) are adopted in this Guide. The recommended upper-bound and lower-bound effective stiffnesses of various RC components are shown in **Tables 1.4** and **1.5** respectively, and were determined after reviewing the typical ranges of axial load ratios, concrete grades, vertical steel ratios and wall lengths in Hong Kong conditions (Su et al., 2014a). Torsional stiffnesses of RC members are particularly low (Tavio and Teng, 2004); hence, a recommended effective cracked torsional stiffness (for compatibility torsion) is also included in the tables for completeness. Definitions of ductility capacity, initial cracked effective stiffness and lower-bound effective stiffness are presented in **Fig. 1.8**. The ductility capacity of the flexural mode (desired failure mode) of each structural member considered in the building model can be determined by computing the ratio of the upper-bound (or initial) effective stiffness to the lower-bound effective stiffness. Such ratio could be further increased if members with higher ductility capacity are adopted in the design.

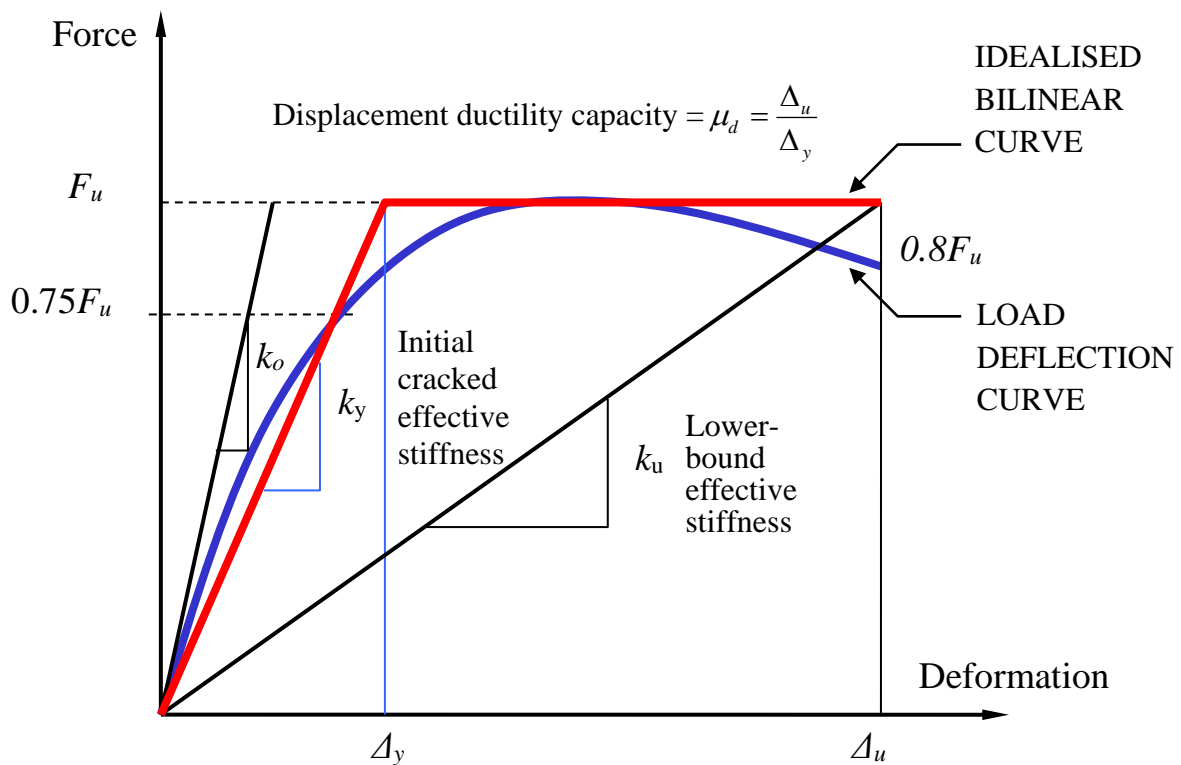
**Table 1.4** Initial cracked member stiffness properties ( $E_c I_c$ )

Type of Member	Member's action			
	Flexural	Axial	Shear	Torsion
Structural Walls	$0.60E_c I_g$	$0.60E_c A_g$	$0.50G_c A_g$	<i>N.A.</i>
Conventional RC Coupling Beams	$0.35E_c I_g$	<i>N.A.</i>	$0.50G_c A_g$	$0.1G_c J$
Transfer Structures	$0.35E_c I_g$	<i>N.A.</i>	$0.50G_c A_g$	$0.1G_c J$
Diaphragms	$0.25E_c I_g$	<i>N.A.</i>	<i>N.A.</i>	<i>N.A.</i>
Moment Frame Beams	$0.35E_c I_g$	<i>N.A.</i>	$0.50G_c A_g$	$0.1G_c J$
Moment Frame Columns	$0.70E_c I_g$	$0.60E_c A_g$	$0.50G_c A_g$	$0.1G_c J$

*N.A.* means not applicable.

**Table 1.5.** Lower-bound stiffness properties ( $E_c I_c$ ) for highly stressed members

Type of Member	Member's action			
	Flexural	Axial	Shear	Torsion
Structural Walls	$0.30E_c I_g$	$0.30E_c A_g$	$0.25G_c A_g$	<i>N.A.</i>
Conventional RC Coupling Beams	$0.20E_c I_g$	<i>N.A.</i>	$0.25G_c A_g$	$0.1G_c J$
Transfer Structures	$0.35E_c I_g$	<i>N.A.</i>	$0.50G_c A_g$	$0.1G_c J$
Diaphragms	$0.25E_c I_g$	<i>N.A.</i>	<i>N.A.</i>	<i>N.A.</i>
Moment Frame Beams	$0.12E_c I_g$	<i>N.A.</i>	$0.25G_c A_g$	$0.1G_c J$
Moment Frame Columns	$0.25E_c I_g$	$0.6E_c A_g$	$0.50G_c A_g$	$0.1G_c J$



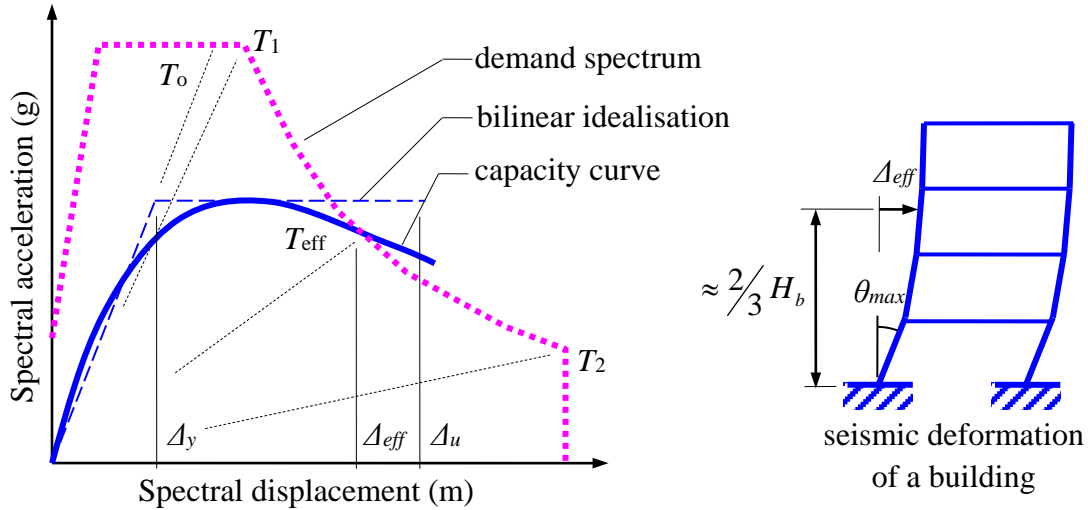
**Figure 1.8** Definitions of member ductility capacity, initial cracked effective stiffness and lower-bound effective stiffness

### 1.8.5 Seismic displacement demand

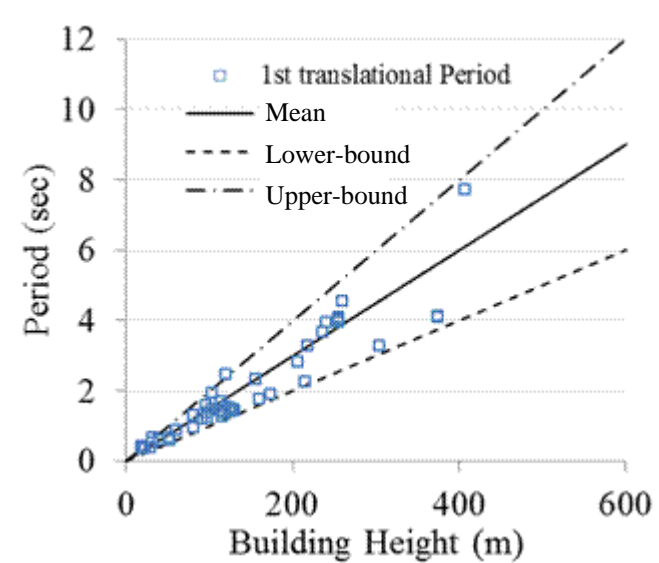
Deformation is a critical parameter by which to assess the degree of seismic damage of structural components and structural systems. Using the capacity spectrum method (Freeman, 2004), the seismic displacement demand ( $\Delta_{eff}$ ) of a low rise (or first mode dominant) building at the effective building height ( $\approx 2H_b/3$ ) can be estimated by the intersection of the capacity curve and the demand spectrum, as shown in **Fig. 1.9**. The capacity of the structure, which is represented by a nonlinear force-displacement curve, can be obtained by way of pushover analysis. The demand of the earthquake ground motion is described by a response spectrum, as shown in **Figs. 1.2** and **1.3**. The radial lines emitting from the origin of the capacity spectrum diagram represent the constant period lines. The figure shows that the seismic displacement



demand depends on the effective structural period ( $T_{eff}$ ), which is equal to  $\beta T_o$  where  $\beta \geq 1$  is the period shift factor and  $T_o$  is the structural period from the initial cracked stiffness model. It is worth noting that the lateral stiffness of a building is primarily controlled by the construction material, the structural system and the building's height, which are often predetermined by the client and design constraints. **Fig. 1.10** shows the initial fundamental periods of RC buildings in Hong Kong obtained from in-situ dynamic tests (Su et al., 2015b). These results clearly illustrate a strong correlation between the structural period and the building height. As a result, once the building height, structural system, construction materials and design return period of an earthquake have been specified, the seismic spectral displacement demands of buildings located within a particular site would only vary within a narrow range.



**Figure 1.9** Deformation demand



**Figure 1.10** Initial first fundamental period of buildings in Hong Kong

The primary seismic design objectives are to avoid premature brittle failure and to accommodate seismic deformation demands. For low rise frame buildings, one may evenly distribute high deformation demands to different floors using the strong-column weak-beam design principle to reduce the maximum inter-storey drift ratio (IDR) demand ( $\theta_{max}$ ) and hence protect gravity load bearing structural components from excessive non-linear deformation. For high-rise regular RC buildings ( $H_b > 50$  m), as the seismic drift

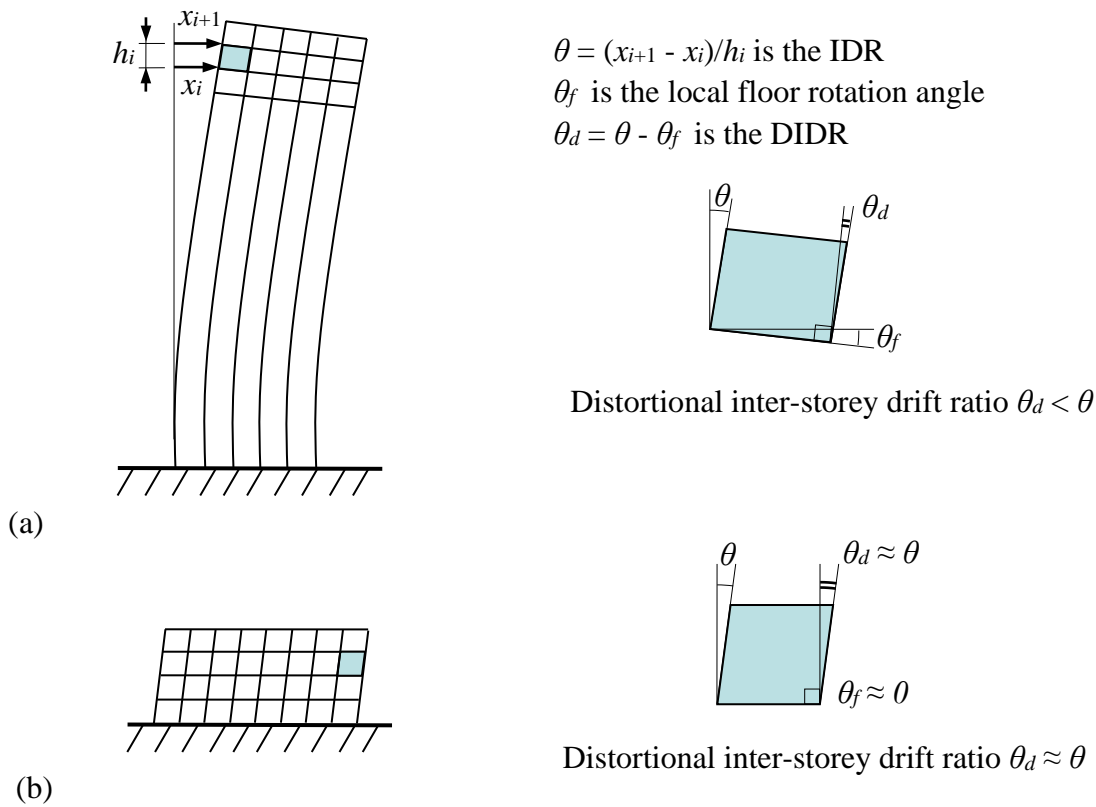
ratio demands are not high, special structural arrangements for minimising IDR are not required in general.

1.8.6 Types of deformation

Deformations can be classified into three types (i) overall building movements, (ii) storey drifts and other internal relative deformations and (iii) rotation of structural components and elements.

Overall building movement can be quantified by roof drift, which enables a qualitative assessment of building performance. Although total building deformation can provide some measure of the significance of P-Δ effects on the response of a building, this is of limited value since structural damage is usually associated with local deformations and distortions.

Inter-storey drift, which is defined as the relative horizontal displacement of two adjacent floors at a given instant in time, is suitable for the assessment of damage to structural and non-structural components of buildings that have not undergone significant floor rotations.



**Figure 1.11** Inter-storey drift ratio and distortional inter-storey drift ratio of (a) a high rise building and (b) a low rise frame building

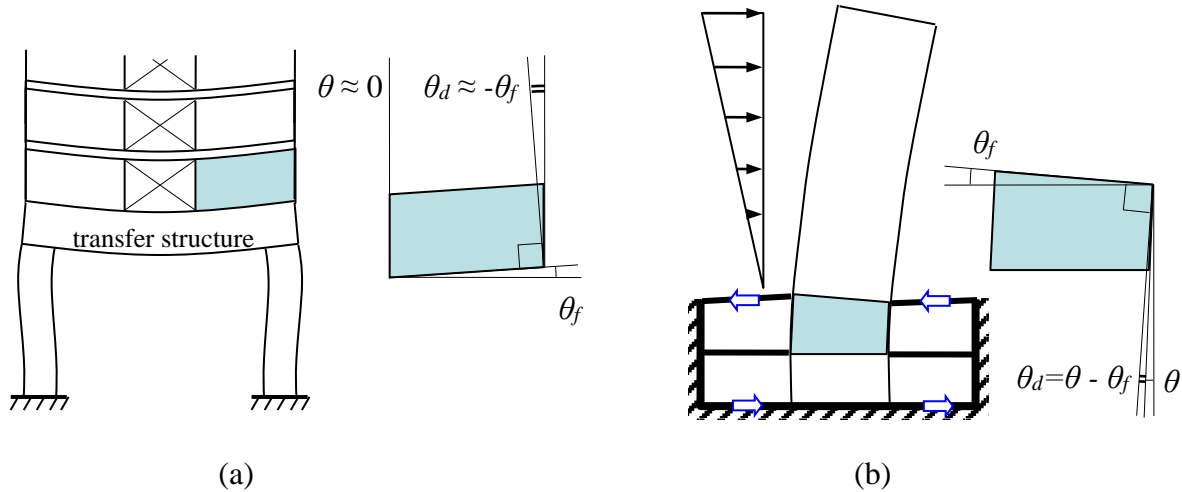
Where vertical deformations occur in the columns and/or walls below, the upper levels of a tall building are rotated as a whole, as illustrated in **Fig. 1.11(a)**. Such rigid body rotation can significantly contribute to the IDR (or  $\theta$ ) but does not induce any damage. The distortional inter-storey drift ratio (DIDR or  $\theta_d$ ), which is calculated by subtracting the floor rotation ( $\theta_f$ ) from the IDR, is an appropriate measure of the in-plane shear deformation of a structural wall or cladding panel. This ratio is particularly suitable for quantifying local distortions and deformations induced by gravity and seismic loads. For regular high-rise

buildings, the DIDR is usually smaller than the IDR. For regular low-rise frame buildings, the DIDR is similar to the IDR (see **Fig. 1.11(b)**) since the floor rotation is generally small.

DIDR is capable of measuring the shear deformation of walls above or below a transfer structure. As illustrated in **Fig. 1.12(a)**, a transfer structure is deflected under gravity loads. Although the IDR above the transfer structure is almost zero, the DIDR is not negligible due to the floor rotation. Such DIDR can reach around 1/500 (or 0.2%) under gravity loads for buildings in Hong Kong. This gravity load induced shear deformation can use up 40% of the shear deformability of conventionally reinforced (non-ductile) shear walls and create huge bending and shear force demands on the wall. As a result, only limited shear and deformation capacities are left with which to resist seismic loads. This explains why transfer structure buildings are more vulnerable to seismic attacks. To enhance the seismic performance of transfer structure buildings in Hong Kong, designers should aim to limit the local rotations of transfer structures at the base of shear walls to not greater than 1/1000 under gravity loads.

As a result of such local rotation, the high shear force induced in walls significantly reduces its shear span. Thus, the seismic response of a slender shear wall, near its base, is similar to that of a squat wall under combined axial and shear loads. For details on how to reduce shear concentration effects, the interested reader may refer to Su and Cheng (2009) and Tang and Su (2015).

An alternative building configuration which can also generate significant local shear and deformation demands at basement levels is that of a tower and basement with structural walls penetrating down to the foundation level, as shown in **Fig. 1.12(b)**. Despite the small IDR, the DIDR is large due to the floor rotation above the basement level. Again, the DIDR but not the IDR is capable of quantifying this shear concentration effect. It is noted that the Council of Tall Buildings and Urban Habitat, USA (CTBUH, 2008) and the Department of Housing and Urban-rural Development of Guangdong Province, PRC (DHUDGP, 2013) also recommend using DIDR to assess the seismic performance of tall buildings.



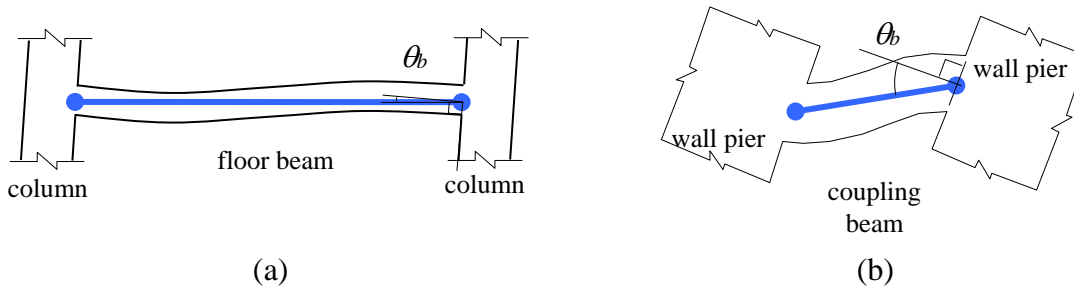
**Figure 1.12** Distortional deformations due to (a) transfer structure and (b) backstay effect

Beam chord rotation (BCR or  $\theta_b$ ) is defined as the rotation between the chord connecting the member end to the point of contraflexure and the tangent at the member end. It can be used to quantify the rotational deformability of floor beams and coupling beams, as shown in **Fig. 1.13**. Many computer programs do

not output BCR directly. For an elastic analysis considering negligible gravity loads, BCR can be estimated from the joint moment  $M_b$  and joint shear  $V_b$  of the beam using Equation (1.4).

$$\theta_b = M_b \left[ \frac{L_v}{3E_c I_c} + \frac{1}{L_v G_c A_v} \right] \quad (1.4)$$

where  $L_v = M_b/V_b$  is the shear span of the beam,  $E_c$  and  $G_c$  are the Young's modulus and shear modulus of concrete,  $I_c$  is the cracked moment of the area (see **Tables 1.4** and **1.5**) and  $A_v$  is the shear area of the section (for rectangular section,  $A_v = 0.8A_g$ ).



**Figure 1.13** Chord rotation of (a) a floor beam and (b) a coupling beam

### 1.8.7 Inter-storey drift ratio, distortional inter-storey drift ratio and beam chord rotation demands

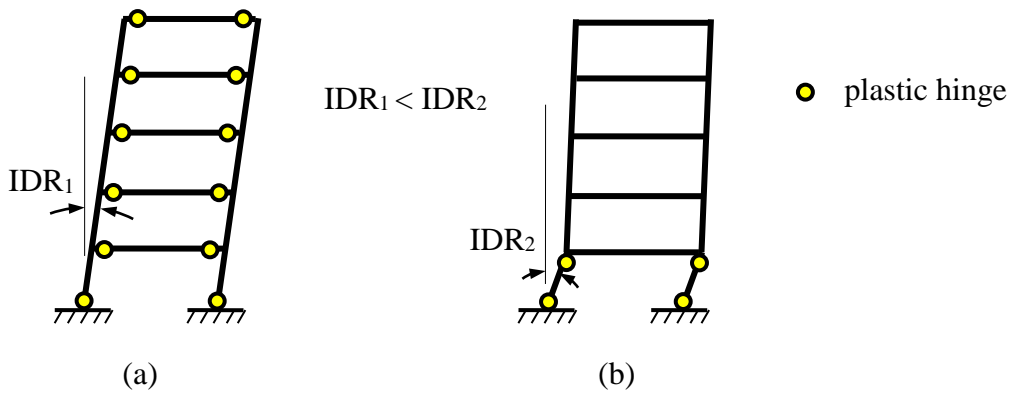
Linear and nonlinear dynamic methods together with the performance based seismic design principle (LATBSDC, 2011) have been used in this Guide to evaluate the seismic deformation demands of RC buildings in Hong Kong. The numerical methods employed and their numerical results are briefly described herein. The use of a simple Timoshenko beam for modelling the dynamic behaviour of a real building has been validated by Boutin et al. (2005) and Su et al. (2016). By calibrating the first and second translational frequencies of buildings using ambient vibration tests, the uniform Timoshenko beam model is capable of simulating higher mode shapes and modal frequencies. Su (2015b) and Su et al. (2015b) integrated the Timoshenko beam model with modal response spectrum analysis in order to assess the seismic performance of buildings with wall, frame and dual systems subjected to occasional and rare earthquakes in Hong Kong. This generalised tool can provide a rapid check of the seismic performance of an immense volume of existing and new buildings. The main assumptions adopted in these analyses are listed below:

1. The building is located on a flat horizontal site;
2. The building remains elastic and is modelled using the initial cracked stiffness model;
3. The building is regular and has no transfer structure;
4. Shear failure is avoided for all RC members; and
5. The extreme torsional irregularity expressed in terms of  $A_2/A_1$  is not greater than 2.3.

The maximum BCR, IDR and DIDR demands under occasional and rare earthquake loads for RC buildings with wall and dual systems, with a consideration of the worst soil site conditions, are summarised in **Table 1.6**.

As low rise buildings are often subjected to large inelastic deformation under rare earthquake actions, the capacity spectrum method (Freeman, 2004), which can provide a simplified means by which to assess the

structural integrity of a building by evaluating its inelastic seismic demands, is used. In this Guide, a beam sway mechanism rather than a column sway mechanism (see **Fig. 1.14**) is adopted in order to avoid soft storey failure and to reduce the maximum IDR demands. Furthermore, the yield IDR of RC columns and the extreme torsional irregularity are taken as 1% and 2.3 respectively. The effects of damping on the reduction of seismic demands (Priestley, 2007) have been considered. It should be noted that the strong-column and weak-beam arrangement should be applied to the seismic design of low-rise frame buildings so as to promote a beam sway mechanism. The maximum BCR, IDR and DIDR demands for low-rise frame structures of more than one storey, evaluated through the capacity spectrum method, are shown in **Table 1.6**, the results of which demonstrate that the seismic IDR demands of low rise RC frame buildings are more pronounced and larger than those of high rise RC wall buildings.



**Figure 1.14** Plastic mechanisms (a) beam sway and (b) column sway

**Table 1.6.** Maximum rotation and drift ratio demands

	Maximum rotation and drift ratio demands (%)					
	Occasional earthquake			Rare earthquake		
	BCR	IDR	DIDR	BCR	IDR	DIDR
Wall system, $H_b \leq 300$ m	0.60	0.55	0.25	1.00	0.90	0.40
Dual system, $H_b \leq 300$ m	1.00	0.80	0.80	2.00	1.50	1.50
Frame system, $H_b \leq 50$ m	1.40	1.40	1.40	3.00	3.00	3.00

It is noted that for non-ductile actions (such as shear in an RC wall), little-to-no inelastic deformation is permissible and component adequacy should be based on force-based checking in order to ensure that the maximum earthquake demands do not exceed nominal capacities. The tabulated seismic deformation demands should not be adopted for the subsequent detailing design if such non-ductile actions have not been thoroughly checked. If a building with a wall system is designed with a transfer structure and the in-plane local rotations of the transfer structure induced by gravity loads have been limited to 0.1%, in the onerous site condition and building configuration, the DIDR as shown in **Table 1.6** may have to be further increased by 0.17% (or 0.25%) under occasional earthquake (or rare earthquake) for the detailing design of the shear walls and columns adjoining the transfer structure.

A secant-stiffness-based incremental response spectrum model that takes into account the yielded properties (cracked effective stiffnesses) of structural members during the incremental substitution

procedure has been developed (Su et al., 2014a) for the analysis of high rise buildings with limited inelastic deformations under earthquake loading. Using this model, Su et al. (2014b) and Leung (2015) respectively analysed a 42-storey residential building with a transfer plate and a 20-storey torsional irregular commercial building under rare earthquake loading. Both buildings were primarily supported by structural walls. The maximum IDR of the commercial building was found to be 0.9% on a deep soil site which is comparable to the drift limit of a wall system, as shown in **Table 1.6**. Leung (2015) further found that some RC wall members would be overstressed if 2% of the longitudinal reinforcement steel ratio was used. For those overstressed RC structural members, their performance could be improved by properly modifying the structural form to minimise the torsional response, adjusting the member dimensions or increasing the reinforcement steel ratios of certain critical members. Furthermore, some wall members might be subjected to high transient tensile loads during rare earthquake actions. However, such tensile forces are deemed acceptable to no-collapse checking as they cause only cracking and not the compressive failure and collapse of the wall members.

As low rise buildings under rare earthquake actions could undergo substantial inelastic deformation, a rigorously nonlinear time history analysis was also carried out using OpenSees (Open System for Earthquake Engineering Simulation, <http://opensees.berkeley.edu/index.php>) software, so as to obtain the maximum IDR demands for four- to six-storey RC framed buildings (Kong, 2015; Wu, 2015; Suen, 2015). The computational results demonstrated that the maximum IDR demand for regular buildings without torsional irregularity was 2.86% which is within the drift limit of 3.0% given in **Table 1.6**.

It is not recommended that structural walls situated within a dual structural system are supported by a transfer structure. However, if wall transfer is unavoidable, the DIDR of the wall panel adjacent to the transfer structure should not exceed the drift ratio limit shown in **Table 1.6**.

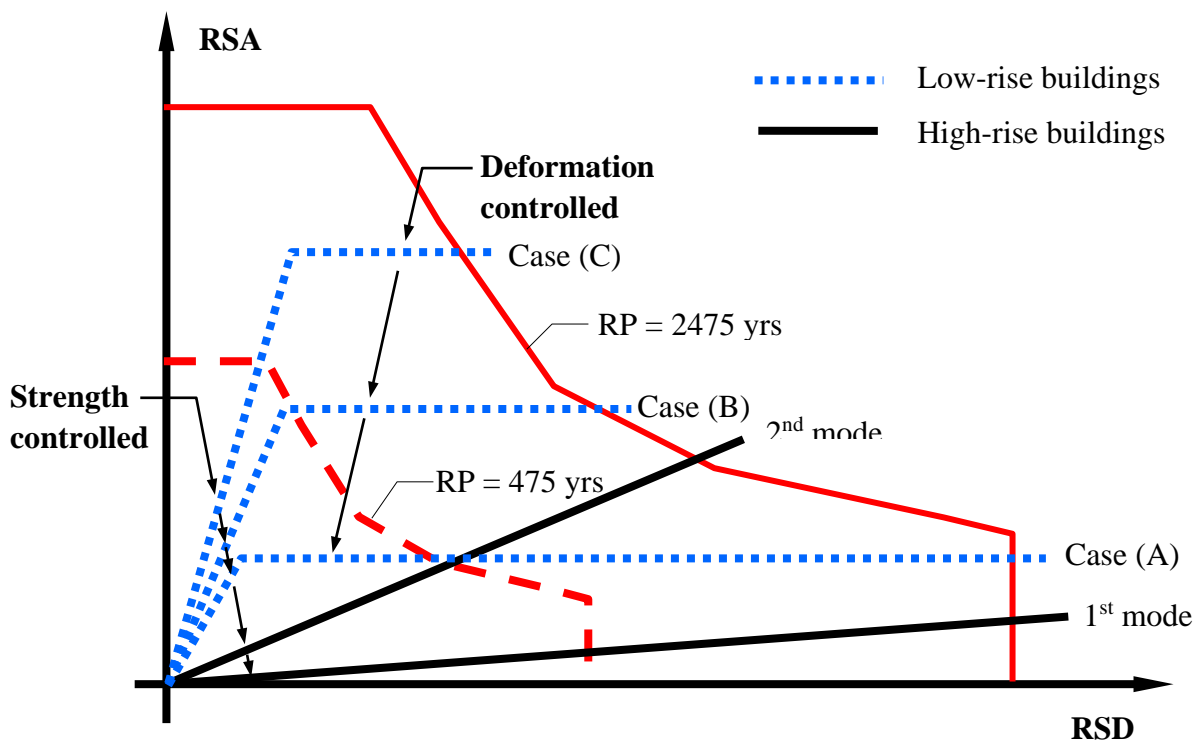
In addition, when the building is located on a sloping site, the seismic response should be amplified appropriately by incorporating topographical effects (BSI, 2004).

#### *1.8.8 Seismic ductility design principles*

The seismic responses of low-rise and high-rise buildings, as illustrated in **Fig.1.15**, are fundamentally different. Under occasional or rare earthquakes, the seismic drift ratio demands on high-rise buildings are relatively small (see **Table 1.6**), while tall buildings respond within an elastic/near elastic range. Force reduction due to ductility effects is no longer applicable. The first mode of the building period usually falls within the displacement controlled (capped) region of the response spectrum, while the second and third modes of the period may fall within the velocity controlled region of the spectrum. Due to their higher mode effects, tall buildings can also be subject to substantial acceleration (or force) demands. Strength rather than ductility or deformability usually governs the members' design. Sufficient shear reinforcement should be provided in columns, walls and beams to avoid premature shear failure. As the force demand of a rare earthquake action is almost double that of an occasional earthquake action, seismic force checking based on occasional earthquake action is insufficient to meet no-collapse requirements in the rare earthquake situation. Shear checking related to rare earthquake loads should be explicitly conducted. To reduce the seismic load, it is advantageous to design a flexible building with longer fundamental periods. Ductile seismic detailing, apart from that in relation to the adjoining of members and transfer structures, is generally unnecessary in Hong Kong conditions.

Low-rise buildings likely experience considerable inelastic deformation, particularly during a rare

earthquake situation. Thus, the use of ductile detailing can improve a building's seismic performance. Global ductile behaviour can help reduce force demands. The degree of inelastic deformation depends on the designed lateral strength capacity of a building. For a building designed with a lateral strength smaller than occasional earthquake demands (see Case (A) in **Fig. 1.15**), the global ductility demand will be very high under rare earthquake loading. Contrary to this, when the lateral strength of a building is high (see Cases (B) and (C)), the global ductility demand will be low. Links are provided to not only increase the shear capacity of structural members but also increase the confinement and hence the ductility of concrete. For high ductility demand cases, the seismic design principles of *strong shear – weak moment*, *strong column – weak beam* and *strong joint – weak member* should be adopted to reduce local ductility demands and avoid the premature failure of structural members.



**Figure 1.15** Difference in seismic responses for low-rise and high-rise buildings

## 1.9 References

- ACI 318 (2014). *Building Code Requirements for Structural Concrete (ACI 318-14) and Commentary*, ACI Committee 318, USA.
- ASCE (2007). *ASCE/SEI Standard 41-06 Seismic Rehabilitation of Existing Buildings*, American Society of Civil Engineers (ASCE), Virginia, USA.
- BD (2013). *Code of Practice for Structural Use of Concrete*, Buildings Department, The Government of the HKSAR.
- Boutin, C, Hans, S, Ibraim, E and Roussillon, P (2005). In situ experiments and seismic analysis of existing buildings part II: seismic integrity threshold. *Earthquake Engineering and Structural Dynamics*, 34(12), 1531-46.
- BSI (2005). *Eurocode 8: Design of Structures for Earthquake Resistance, Part 3: Assessment and Retrofitting of Buildings*, British Standards Institute, UK.
- BSI (2004). *Eurocode 8: Design of Structures for Earthquake Resistance, Part 5: Foundations, Retaining Structures and Geotechnical Aspects*, British Standards Institute, UK.
- CSA (2004). *CSA A.23.3-04: Design of Concrete Structures*, Canadian Standards Association (CSA), Ontario.
- CTBUH (2008). *Recommendations for the Seismic Design of High-rise Buildings*, Council of Tall Buildings and Urban Habitat, Chicago, IL.
- DHUDGP (2013). *Technical specification for concrete structures of tall building*, DBJ 15-92-2013, Department of Housing and Urban-rural Development of Guangdong Province, PRC.
- Freeman SA (2004). Review of the development of the capacity spectrum method, *ISET Journal of Earthquake Technology*, Paper No. 438, **41** (1): 1-13
- Kong LC (2015). *Strength Capacity of Reinforced Concrete Beam-column Joints*, Final Year Project Report, Department of Civil Engineering, The University of Hong Kong.
- Leung KT (2015). *Quantification of Seismic Local Ductility Demand of Structural Members in RC Buildings*, Final Year Project, Department of Civil Engineering, The University of Hong Kong.
- LATBSDC (2011). *An Alternative Procedure for Seismic Analysis and Design of Tall Buildings Located in the Los Angeles Region*, Los Angeles Tall Buildings Structural Design Council, USA.
- PEER/ATC-72-1 (2010). *Modeling and Acceptance Criteria for Seismic Design and Analysis of Tall Buildings*, Applied Technology Council/Pacific Earthquake Engineering Research Center, Redwood City, California.



- Priestley MJN, Calvi GM and Kowalsky MJ (2007), *Displacement-Based Seismic Design of Structures*, IUSS Press, Pavia, Italy.
- Su RKL and Cheng MH (2009). Earthquake induced shear concentration in shear walls above transfer structures, *The Structural Design of Tall and Special Buildings* **18**(6): 657-671.
- Su RKL (2015a). Mechanical properties of local concrete, *Annual Concrete Seminar 2015, Concrete: From Production to Recycling*, Standing Committee on Concrete Technology, Civil Engineering and Development Department, The Government of the HKSAR, 29 April 2015.
- Su RKL (2015b). Seismic Demands on RC Tall Buildings in Hong Kong under Rare Earthquake Action, *1-Day Workshop The State-of-the-practice of Tall Building Design and Construction*, The American Society of Civil Engineers, Hong Kong Section, 22 May 2015.
- Su RKL, Lee CL, Tsang HH and Tang TO (2014a). *Final Report on Provision of Consultancy Services of Development of Design Reference for Enhanced Ductility Design of Housing Authority Buildings*, Agreement No. CB20130721, Hong Kong Housing Authority, The Government of the HKSAR.
- Su RKL, Looi DTW, Tang TO and Law CW (2014b). Performance based seismic design for tall buildings in Hong Kong, *The Proceedings of Advances in Earthquake Engineering*, Joint Structural Division Annual Seminar 2014, 19 May 2014, Hong Kong, p107-131.
- Su RKL, Lee CL, He CH, Tsang HH and Law CW (2015a). Rare earthquake response spectra for typical site conditions in Hong Kong, *HKIE Transactions*, **22**(3): 179-191.
- Su RKL, Tang TO, Lee CL and Tsang HH (2015b). Simplified seismic assessment of RC buildings in Hong Kong under occasional earthquake action, *CIC Research Journal*, **2**: 45-54.
- Su RKL, Tang TO and Liu KC (2016). Simplified seismic assessment of tall buildings using non-uniform Timoshenko beam model in low-to-moderate seismicity regions, *Engineering Structures*, **120**, p116-132.
- Suen KW (2015). *Seismic Local Ductility Demand of Structural Members in Low-Rise Buildings*, MSc Thesis, Department of Civil Engineering, The University of Hong Kong.
- Tang TO and Su RKL (2015). Gravity-induced shear force in reinforced concrete walls above transfer structures, *Proceedings of the Institution of Civil Engineers-Structures & Buildings*, **168**(1): 40-55.
- Tavio and Teng S (2004). Effective torsional rigidity of reinforced concrete members, *ACI Structural Journal*, **101**, p252-260.
- Wu WJ (2015). *Strength Capacity of Reinforced Concrete Beam-column Joints*, MSc Thesis, Department of Civil Engineering, The University of Hong Kong.

## **2 WALL SYSTEMS**

### **2.1 Scope**

The detailing provisions described herein apply to RC buildings with heights not exceeding 300 m, with structural RC walls acting as the primary earthquake force-resisting system.

Under occasional earthquake, the maximum DIDR demand of regular walled buildings without transfer structures should not exceed 0.25%. Such a requirement is deemed to be satisfied if the maximum IDR subjected to occasional earthquake is less than 0.55%.

Under rare earthquake, when no-collapse limit state is explicitly considered, the IDR and DIDR demands of regular walled buildings are increased to 0.9% and 0.4% respectively.

If a wall system together with a transfer structure is utilised and the in-plane local rotations of the transfer structure due to gravity loads have been limited to 0.1%, the aforementioned DIDR demands may be increased to 0.42% under occasional earthquake or 0.65% under rare earthquake for the detailing design of the shear walls and columns adjoining the transfer structure.

The detailing provisions presented in this Chapter aim to provide sufficient drift ratio capacity for RC members to cope with the aforementioned deformation demands.

### **2.2 Detailing considerations**

In buildings with RC walls acting as the primary earthquake force-resisting system, the majority portion of the lateral seismic loads is resisted by the structural walls due to their high lateral stiffness. The seismic response of a building is controlled by the strength, stiffness and deformability of its RC walls rather than by the flexible RC columns attached to the wall system. To ensure the survival of the building after a rare earthquake attack, structural walls should have sufficient strength and deformability to resist the corresponding seismic demands.

In order to avoid wall shear failure, which may trigger the catastrophic partial or total collapse of a building, the shear strength of its walls should be designed with sufficient shear area and reinforcement to resist rare earthquake actions. Currently, the latest design code in Hong Kong (BD, 2013) does not require the shear checking of RC walls for buildings under combined wind and gravity load effects. The seismic shear checking of RC walls may follow other international standards or design guidelines such as ACI 318 (2014) and LATBSDC (2011). It should be noted that the National Research Council of Canada (NRC 2010), the Los Angeles Tall Buildings Structural Design Council (LATBSDC, 2011) and the Council of Tall Buildings and Urban Habitat (CTBUH, 2008) already explicitly require designs to take account of the seismic shear demand associated with a rare earthquake with a return period of 2475 years. In view of the widespread structural damage inflicted by the Northridge earthquake, a redundancy

coefficient of 1.3 has been introduced to ASCE 07-02 (ASCE 2002) so as to encourage the design of more redundant RC shear wall buildings.

Despite the strength design, appropriate seismic detailing should be provided to enhance the deformability of structural walls. The drift capacity of structural walls primarily depends on the failure mode, the shear span-to-depth ratio (SDR), the axial load ratio (ALR) and the reinforcement arrangements in place. In order to ensure walls have sufficient deformability against rare earthquake loads, brittle shear failures should be avoided when conducting no-collapse limit state checks. In other words, the seismic shear capacity of walls should be higher than the seismic shear demand associated with rare earthquake loads.

The SDR is defined in Equation (2.1).

$$SDR = \frac{M}{Vh_w} \quad (2.1)$$

where  $M$  and  $V$  are the end moment and shear respectively and  $h_w$  is the depth of the wall. In general, the deformability of a wall reduces as the SDR decreases. When the SDR is less than 1.5, the wall usually fails in shear mode. For coupled shear walls and walls adjoining transfer structures, the shear force demand is amplified and the SDR of those walls is usually less than one.

In the literature, ALR is defined as

$$ALR = \frac{N_{work}}{f'_{c,m} A_g} \quad (2.2)$$

where  $N_{work}$  is the unfactored axial load,  $f'_{c,m}$  is the mean (or expected) cylinder strength of concrete and  $A_g$  is the sectional area of wall. In the Code of Practice for Structural Use of Concrete (BD 2013), the axial compression ratio  $N_{cr}$  of ductile walls is limited to

$$N_{cr} = \frac{N_{ult}}{0.45 f_{cu,k} A_g} \leq 0.75 \quad (2.3)$$

where  $N_{ult}$  is the factored gravity axial load and  $f_{cu,k}$  is the characteristic cube strength of concrete. Assuming  $1.45 N_{work} = N_{ult}$ ,  $f'_{c,m} = 1.4 f'_{c,k}$  and  $f'_{c,k} = 0.85 f_{cu,k}$ , Equation (2.3) leads to  $ALR \leq 0.2$ . Such a small ALR can minimise the potential risk of the compression failure of walls under severe earthquake loads and should be adopted in the design of structural walls adjoining transfer structures.

Extensive test results (Greifenhagen and Lestuzzi, 2005; Kuang and Ho, 2007 and 2008) on squat walls (i.e.  $SDR \leq 1.5$ ) with non-seismic detailing (i.e. without boundary element) and  $ALR \geq 0.05$  demonstrate that the ultimate drift ratio is generally higher than 0.5%, which is considerably higher than the maximum DIDR demand (0.4%) for regular wall buildings under rare earthquake loads.

Confined boundary elements are the edge regions of walls with concentrated longitudinal steel and with confining transverse hoops, and are normally used in shear walls experiencing high compressive stresses and strains at the end fibre. Besides enhancing the bending and shear strengths of walls, slender cantilever shear walls with boundary elements behave in a more ductile manner, assuming that the inelastic response is dominated by flexure at critical yielding sections. Past experimental results have demonstrated that the

use of boundary elements in slender shear walls ( $SDR > 2$ , dominated by flexural action) can improve ductile behaviour (Hube et al., 2014). It is noted that adequately detailed transverse link spacing between longitudinal bars located at boundaries should be provided in order to avoid potential bar buckling damage when subjected to load reversal (Hilson et al., 2014). Contrary to this, the use of boundary elements in squat walls or walls with a  $SDR \leq 1.5$  can only moderately increase shear capacity but not significantly improve the ductility of walls. However, as walls connected to a transfer structure usually experience very high seismic and gravity shear demands, a stringent Type 3 confined boundary element, as stipulated in the Code of Practice for Structural Use of Concrete 2013 (BD 2013), is recommended.

For other structural components in walled buildings, such as columns and beams together with beam-column joints, the drift capacities are usually much higher than 0.65% even without seismic detailing (Xiong, 2001; Lam et al., 2003; Huang, 2003; Li, 2003; Ho, 2003; Kuang and Wong, 2005; Wong and Kuang, 2008; Leung et al., 2016). These components are not critical if they are properly tied to the seismically protected wall system.

## 2.3 Structural walls

The detailing provisions described here refer to conventional RC walls with a length to thickness ratio of 4 or more and in which the section and reinforcement have been designed to resist seismic forces.

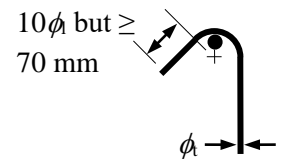
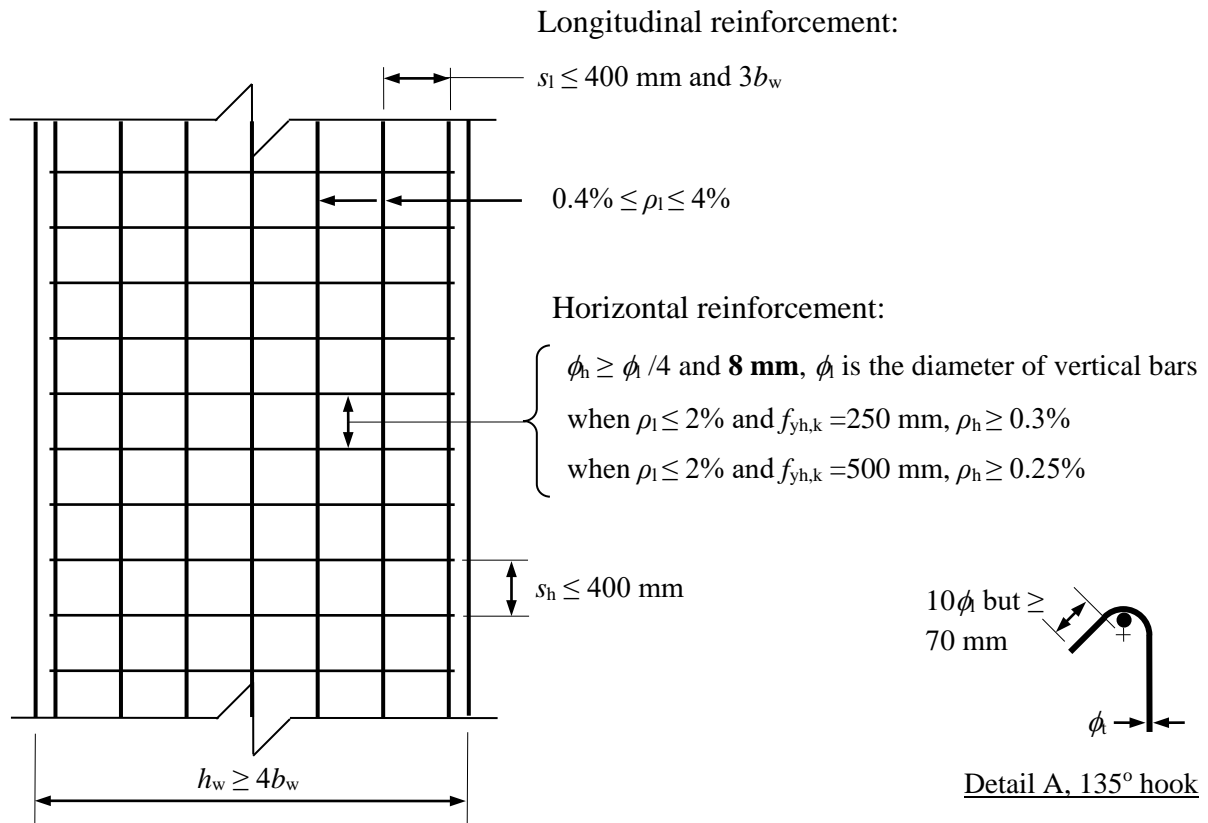
The vertical, horizontal and transverse detailing requirements for conventional RC walls are summarised in **Table 2.1**. Reinforcement provided for shear strength should be continuous and uniformly distributed across the shear plane. Uniform distribution of reinforcement across the height and horizontal length of the wall helps control the width of inclined cracks. For walls subjected to substantial in-plane shear forces, two layers of reinforcement should be provided in order to reduce the fragmentation and premature deterioration of the concrete under load reversals into the inelastic range (Fanella, 2007). Furthermore, for buildings with transfer structures, the definition of critical zones and boundary element requirements for walls adjoining transfer structure are summarised in **Table 2.2**.

**Table 2.1.** Detailing requirements for conventional RC walls

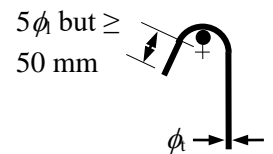
Requirements	Clause No. (BD 2013)	Figure No.
<p>Vertical reinforcement:</p> <p>The minimum and maximum percentages of vertical reinforcement <math>\rho_1</math> based on the concrete cross-sectional area of a wall are 0.4% and 4% respectively.</p> <p><b>Two layers of vertical reinforcement are recommended.</b></p> <p>Vertical bar spacing <math>s_1</math> shall not exceed three times the wall thickness <math>b_w</math> or 400 mm, whichever is the lesser.</p>	9.6.2	2.1
<p>Horizontal reinforcement:</p> <p>Where the main vertical reinforcement is used to resist compression and does not exceed 2% of the concrete area, at least the following percentages of horizontal reinforcement <math>\rho_h</math> should be provided:</p>	9.6.3	

<p>(a) <math>f_{yh,k} = 250 \text{ N/mm}^2</math>: 0.30% of concrete cross-sectional area; and  (b) <math>f_{yh,k} = 500 \text{ N/mm}^2</math>: 0.25% of concrete cross-sectional area.</p> <p>Reinforcement spacing <math>s_h</math> should be evenly spaced at no more than 400 mm. The diameter <math>\phi_h</math> should be not less than one-quarter of the size of the vertical bars <math>\phi_l</math> and not less than <b>8 mm</b>.</p>		
<p>Transverse reinforcement:</p> <p>When the vertical compression reinforcement exceeds 2%, links with a diameter <math>\phi_l</math> at least <b>8 mm</b> or one-quarter the size of the largest compression bar should be provided through the thickness of the wall.</p> <p>The spacing of links <math>s_t</math> should not exceed twice the wall thickness <math>b_w</math> in either the horizontal or vertical direction.</p> <p>In the vertical direction it should be not greater than 16 times the bar diameter <math>\phi_l</math>.</p> <p>All vertical compression bars should be enclosed by a link.</p> <p>No bar should be further than 200 mm from a restrained bar, at which a link passes round the bar at an included angle of not more than <math>90^\circ</math>.</p>	<p>9.6.4</p>	

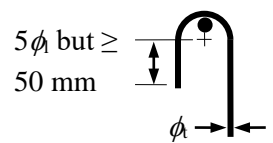
## Wall elevation



Detail A, 135° hook



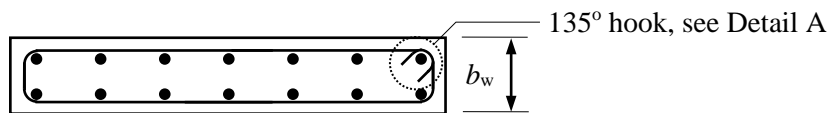
Detail B, 150° hook



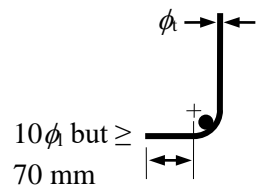
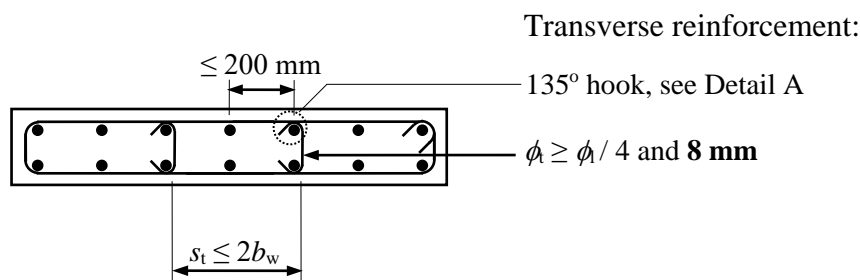
Detail C, 180° hook

## Wall sections

(a)  $\rho_l \leq 2\%$



(b)  $\rho_l > 2\%$



Detail D, 90° hook

Note: vertical spacing of transverse reinforcement  $\leq 2b_w$  and  $16\phi$

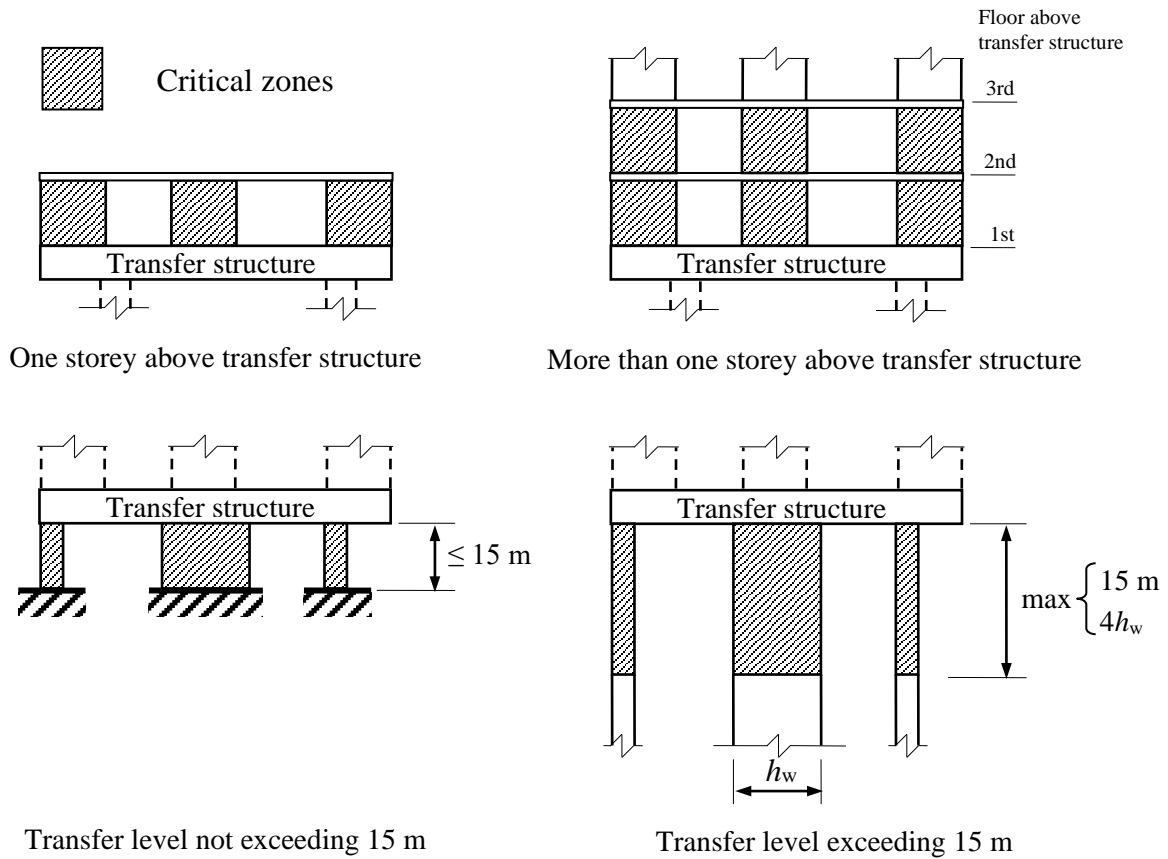
**Figure 2.1** Reinforcement requirements for conventional RC walls

**Table 2.2.** Critical zones and design requirements for ductile walls adjoining a transfer structure

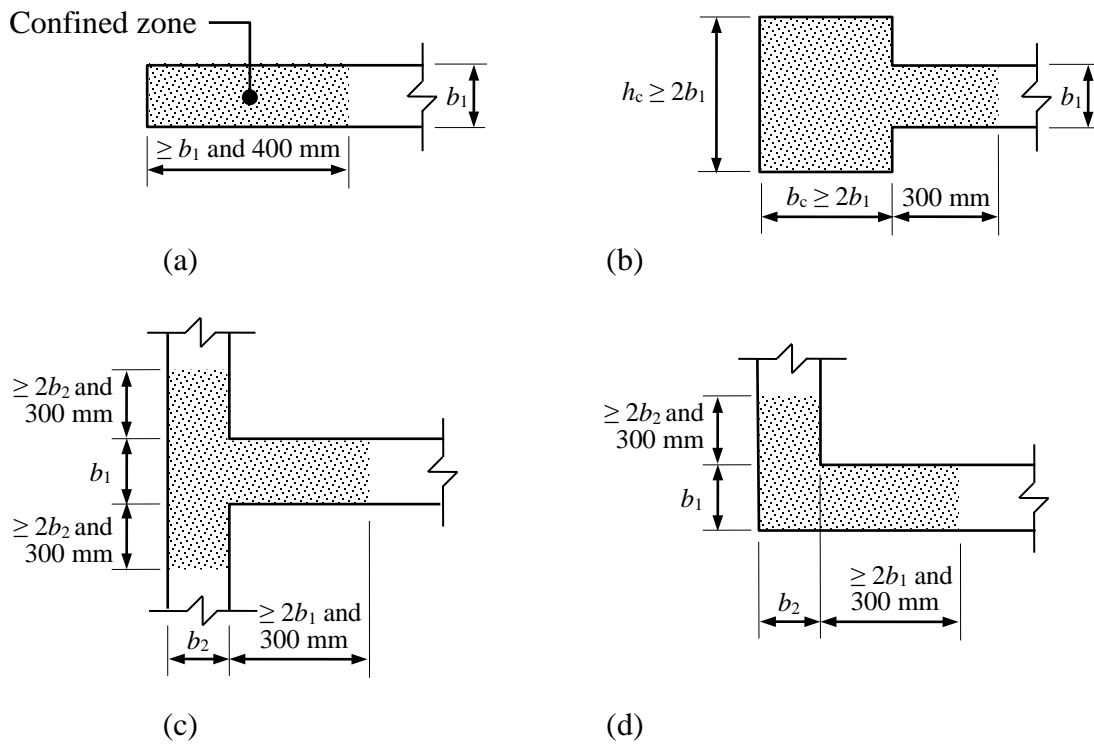
Requirements	Clause No. (BD 2013)	Figure No.
<p><b><u>Critical zones</u></b></p> <p>(1) <b>Walls supported by a transfer structure with one storey above the transfer structure:</b> The critical zone should extend from the top surface of the transfer structure to the ceiling of the first floor above the transfer structure.</p> <p>(2) <b>Walls supported by a transfer structure with more than one storey above the transfer structure:</b> The critical zone should extend from the top surface of the transfer structure to the ceiling of the second floor above the transfer structure.</p> <p>(3) <b>Walls supporting a transfer structure with a height not exceeding 15 m:</b> The critical zone should extend from the support of the wall to the soffit of the transfer structure.</p> <p>(4) <b>Walls supporting a transfer structure with a height exceeding 15 m:</b> The critical zone should extend from the soffit of the transfer structure supported by the wall to 15 m below or four times the larger wall sectional dimension, whichever is the greater.</p>	N.A.	2.2
<p><b><u>Axial compression ratio</u></b></p> <p>when <math>0.4\% &lt; \text{DIDR} \leq 0.65\%</math> (under rare earthquake), <math>N_{cr} \leq 0.55</math>; when <math>\text{DIDR} \leq 0.40\%</math> (under rare earthquake), <math>N_{cr} \leq 0.75</math>.</p>	N.A.	N.A.
<p><b><u>Confined boundary elements</u></b></p> <p>The extent of this confined boundary element is illustrated in <b>Fig. 2.3</b>.</p> <p>This confined boundary element should be provided with vertical reinforcement satisfying the following requirements (<b>Fig. 2.4</b>):</p> <p>(1) <math>\rho_1</math> should not be less than 1% of the sectional area of the structural boundary element;</p> <p>(2) <math>\rho_1</math> should not be more than 2% when <math>0.4\% &lt; \text{DIDR} \leq 0.65\%</math> (under rare earthquake);</p> <p>(3) <math>\phi</math> is not smaller than 16 mm and the number of bars is not less than six;</p> <p>(4) spacing <math>s_1</math> should not exceed 150 mm;</p> <p>(5) each vertical bar is tied with links <b>or ties</b> of at least 12 mm</p>	9.9.3.2	2.3 and 2.4

<p>diameter and vertical spacing should not exceed 150 mm; and</p> <p><b>(6) links and ties should be adequately anchored by means of 135° hooks. Where there is adequate confinement to prevent the end anchorage of the link from “kick off”, the 135° hook may be replaced by other standard hooks.</b></p>		
<p><u>Unconfined web</u></p> <p>Vertical reinforcement:</p> <p>The minimum and maximum percentages of vertical reinforcement <math>\rho_l</math> based on the concrete cross-sectional area of a wall are 0.4% and 4% respectively.</p> <p><b>When <math>0.4\% &lt; \text{DIDR} \leq 0.65\%</math> (under rare earthquake), <math>\rho_l \leq 2\%</math>;</b></p> <p><b>Two layers of vertical reinforcement are recommended.</b></p> <p>Vertical bar spacing <math>s_l</math> shall not exceed three times the wall thickness <math>b_w</math> or 400 mm, whichever is the lesser.</p>	9.6.2	
<p>Horizontal reinforcement:</p> <p>Where the main vertical reinforcement is used to resist compression and does not exceed 2% of the concrete area, at least the following percentages of horizontal reinforcement <math>\rho_h</math> should be provided:</p> <p>(a) <math>f_{yh,k} = 250 \text{ N/mm}^2</math>: 0.30% of concrete cross-sectional area; and</p> <p>(b) <math>f_{yh,k} = 500 \text{ N/mm}^2</math>: 0.25% of concrete cross-sectional area.</p> <p>Reinforcement spacing <math>s_h</math> should be evenly spaced at no more than 400 mm. The diameter <math>\phi_h</math> should be not less than one-quarter of the size of the vertical bars <math>\phi</math> and not less than <b>8 mm</b>.</p>	9.6.3	2.4
<p>Transverse reinforcement:</p> <p>When the vertical compression reinforcement exceeds 2%, links with a diameter <math>\phi_l</math> at least <b>8 mm</b> or one-quarter the size of the largest compression bar should be provided through the thickness of the wall.</p> <p>The spacing of links <math>s_t</math> should not exceed twice the wall thickness <math>b_w</math> in either the horizontal or vertical direction.</p> <p>In the vertical direction, it should be not greater than 16 times the bar diameter <math>\phi</math>.</p> <p>All vertical compression bars should be enclosed by a link.</p> <p>No bar should be further than 200 mm from a restrained bar, at which a link passes round the bar at an included angle of not more than 90°.</p>	9.6.4	



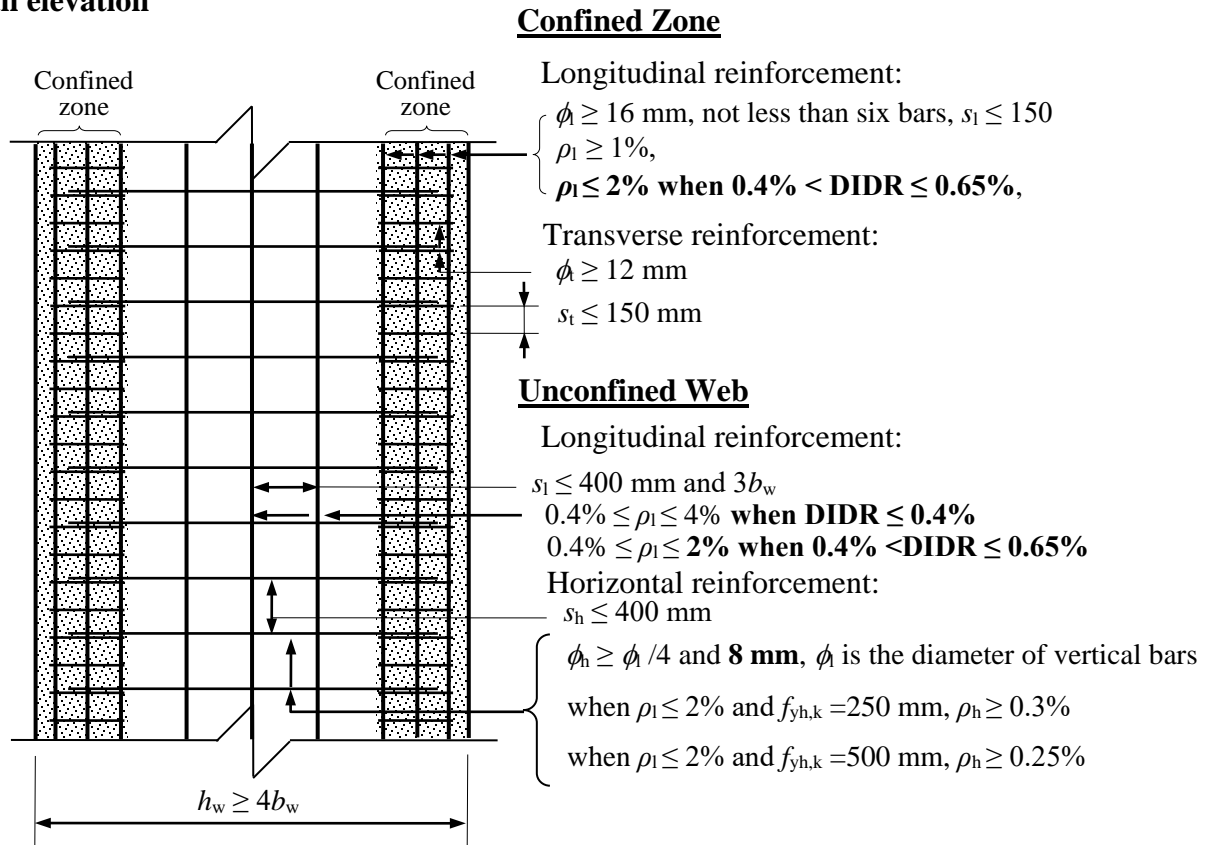


**Figure 2.2** Critical zones of walls adjoining a transfer structure

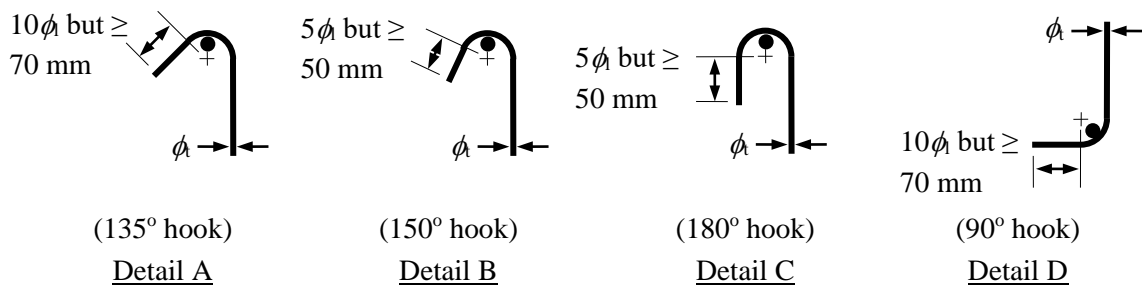
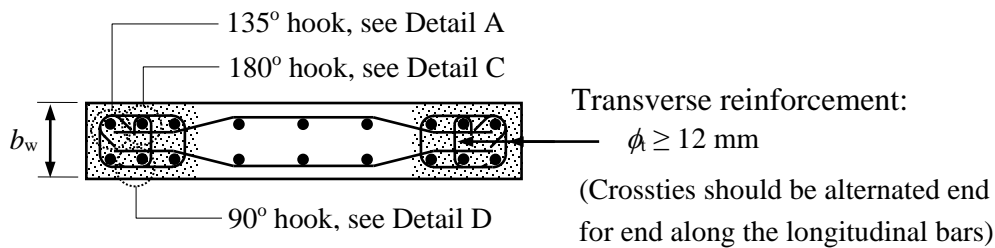


**Figure 2.3** Confined boundary elements (a) hidden column, (b) edge column, (c) wing wall and (d) L-shaped wall

## Wall elevation



## Wall sections



**Figure 2.4** Reinforcement requirements for ductile RC walls

## 2.4 Coupling beams

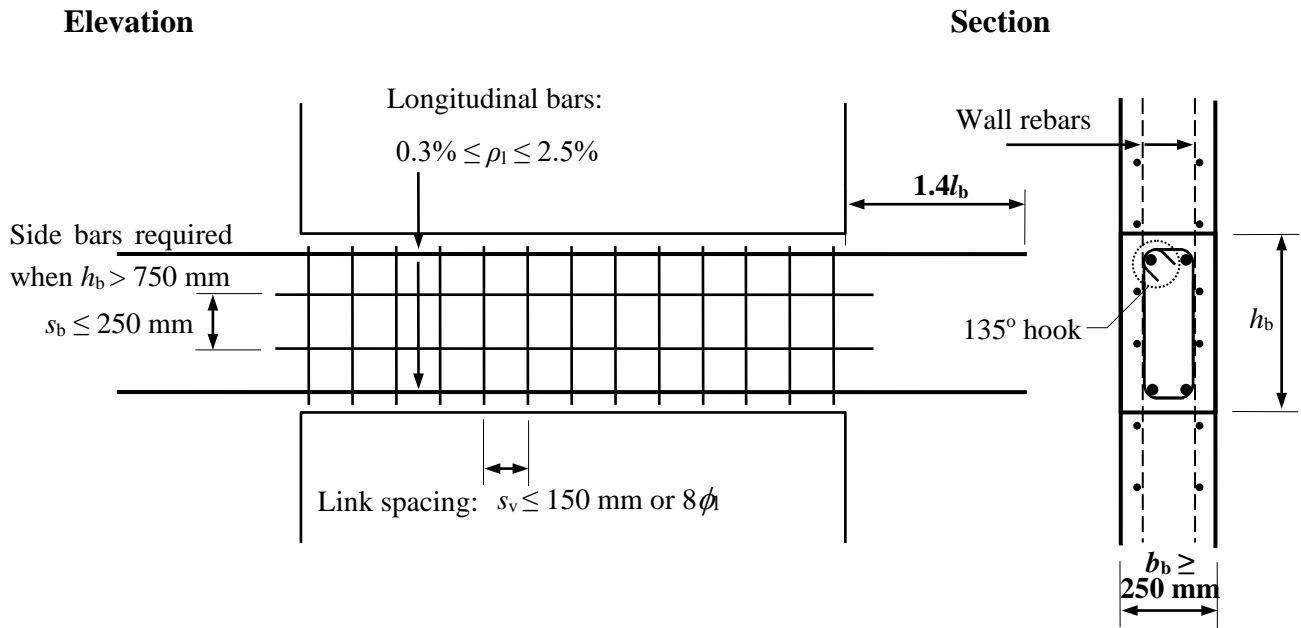
Coupling beams are used to connect shear walls with openings such as windows, corridors and stairs. Their span-to-depth ratios are usually smaller than 4. They are subjected to moments and shears under seismic actions in the plane of their walls. According to the predicted seismic demand of wall buildings in Hong Kong during a rare earthquake, the maximum chord rotation demand of coupling beams is 1%, which is less than the minimum chord rotation capacity of 1.5% taken from past experimental results. Hence, yielding but not failure of coupling beams in wall buildings is expected. The RC detailing provisions of conventional RC coupling beams are presented in **Table 2.3**.

The Hong Kong Code of Practice for Structural Use of Concrete 2013 (BD 2013) does not separately provide detailing provisions for floor beams and coupling beams. As potential plastic hinges may form at the beam ends and the size of these plastic hinges extends over almost the entire length of the beam, this Guide suggests adopting the ductile requirements of the critical region of the RC floor beams for coupling beams.

Furthermore, in order to ensure the coupling beams have limited ductility capacity without premature brittle failure, the shear capacity of the beam should be designed to be higher than its flexural capacity. The minimum thickness of the coupling beams should be at least 250 mm to allow wall and beam reinforcement to be properly fixed and the concrete placed (SRIA, 2015) (see **Fig. 2.5**).

**Table 2.3.** Conventional coupling beam detailing requirements

Requirements	Clause No. (BD 2013)	Figure No.
<p>Longitudinal reinforcement:</p> <p>The minimum and maximum percentages of longitudinal reinforcement <math>\rho_l</math> based on the concrete cross-sectional area of a coupling beam are 0.3% and 2.5% respectively (clause 9.9.1.2).</p> <p>The clear horizontal distance between adjacent longitudinal bars should not exceed <math>70,000 \beta_b / f_{yl} \leq 300</math> mm, where <math>\beta_b</math> and <math>f_{yl}</math> are the redistribution ratio and estimated service stress in the longitudinal reinforcement respectively, as defined in clause 9.2.1.4.</p> <p><b>Curtailement of the longitudinal reinforcement is not recommended.</b></p> <p><b>The minimum anchorage length is recommended to be <math>1.4 l_b</math>, where <math>l_b</math> is the ultimate anchorage bond length.</b></p>	9.2.1.4 and 9.9.1.2	2.5
<p>Transverse reinforcement:</p> <p>The centre-to-centre spacing of links <math>s_v</math> along a beam shall not exceed the larger of 150 mm or eight times the longitudinal bar diameter <math>\phi</math> (clause 9.9.1.3).</p> <p>At right-angles to the span, the horizontal spacing should be such that no longitudinal tension bar is more than 150 mm from a vertical leg (clause 9.2.2).</p> <p>Links should be adequately anchored by means of <math>135^\circ</math>, <b><math>150^\circ</math></b> or <math>180^\circ</math> hooks, in accordance with clause 8.5.</p>	8.5, 9.2.2 and 9.9.1.3	
<p>Side bars for beams exceeding 750 mm overall depth:</p> <p>The minimum diameter of the bars must be <math>\geq \sqrt{(s_b b_b / f_{yw,k})}</math>, where <math>s_b \leq 250</math> mm is the bar spacing, <math>b_b</math> is the beam width, or 500 mm if <math>b_b</math> exceeds 500 mm, and <math>f_{yw,k}</math> is the characteristic yield strength of the side bar.</p>	9.2.1.2	



**Figure 2.5** Reinforcement requirements for conventional coupling beams

## 2.5 RC columns

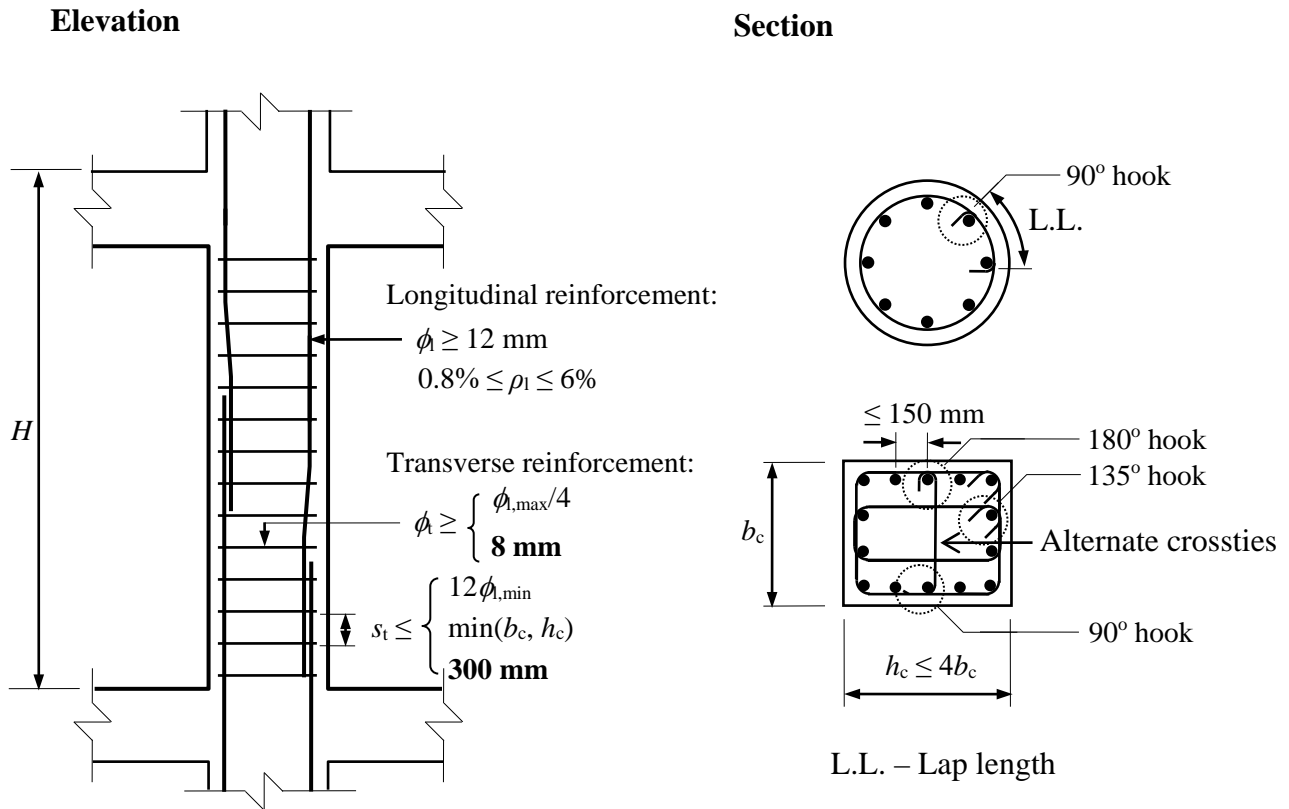
The detailing provisions are applicable to conventional columns in which the larger dimension  $h_c$  is not greater than four times the smaller dimension  $b_c$ . The detailing requirements for the seismic design of conventional columns are summarised in **Table 2.4** and **Fig. 2.6**.

**Table 2.4.** Detailing requirements of conventional RC columns

Requirements	Clause No. (BD 2013)	Figure No.
<p>Longitudinal reinforcement:</p> <p>The minimum and maximum percentages of longitudinal reinforcement <math>\rho_l</math> based on the concrete cross-sectional area of a vertically-cast column are 0.8% and 6.0% respectively.</p> <p>The bar diameter <math>\phi</math> should not be less than 12 mm.</p> <p>The minimum number of longitudinal bars in a column should be four in rectangular columns and six in circular columns. In columns with a polygonal cross-section, at least one bar should be placed at each corner.</p> <p>At the laps, the sum of the reinforcement sizes in a particular layer should not exceed 40% of the breadth of the section at that location.</p>	9.5.1	2.6
<p>General requirements of transverse reinforcement:</p> <p>The diameter of the transverse reinforcement <math>\phi_t</math> should not be less than <b>8 mm</b> or one-quarter of the diameter of the largest longitudinal bar <math>\phi_l</math>, whichever is the greater.</p> <p>The spacing of transverse reinforcement <math>s_t</math> along a column should not exceed the least of the following:</p> <p>(a) 12 times the diameter of the smallest longitudinal bar;</p> <p>(b) the lesser dimension of the column;</p> <p>(c) <b>300 mm</b>.</p>	9.5.2.1	
<p>Transverse reinforcement for rectangular or polygonal columns:</p> <p>All corner bars and alternate bars (or bundles) in an outer layer of reinforcement should be supported by links, with or without crossties, passing around the bars and have an included angle of not more than <math>135^\circ</math>. No bar within a compression zone should be further than 150 mm from a restrained bar.</p> <p>Links should be adequately anchored by means of hooks bent through an angle of not less than <math>135^\circ</math>. Crossties should be adequately anchored by means of hooks bent through an angle of not less than <math>135^\circ</math> at one end and <math>90^\circ</math> at the other end, and should be alternated end for end along the longitudinal bars.</p>	9.5.2.2	
<p>Transverse reinforcement for circular columns:</p> <p>Spiral transverse reinforcement should be anchored by either welding to the previous turn, in accordance with clause 8.7, or by terminating the spiral with at least a <math>90^\circ</math> hook bent around a longitudinal bar and the hook being no more than 25 mm from the previous turn.</p>	9.5.2.3	

Circular links should be anchored by either a mechanical connection or a welded lap, in accordance with clause 8.7, or by terminating each end of the link with at least a 90° hook bent around a longitudinal bar and overlapping the other end of the link.

Spiral or circular links should not be anchored by straight lapping.



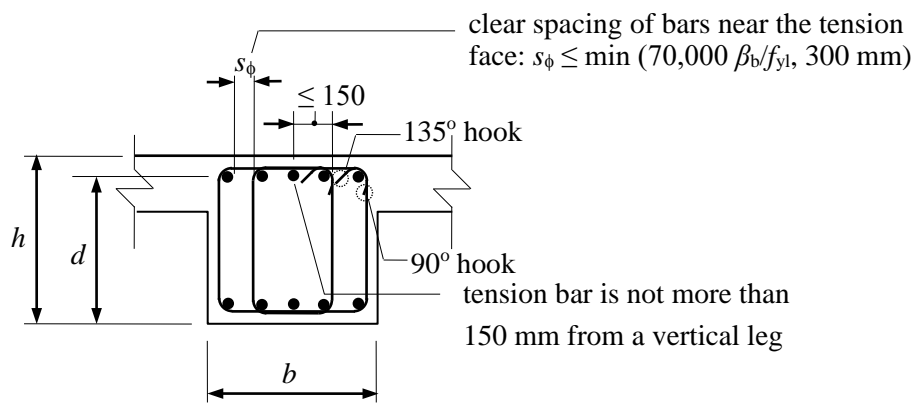
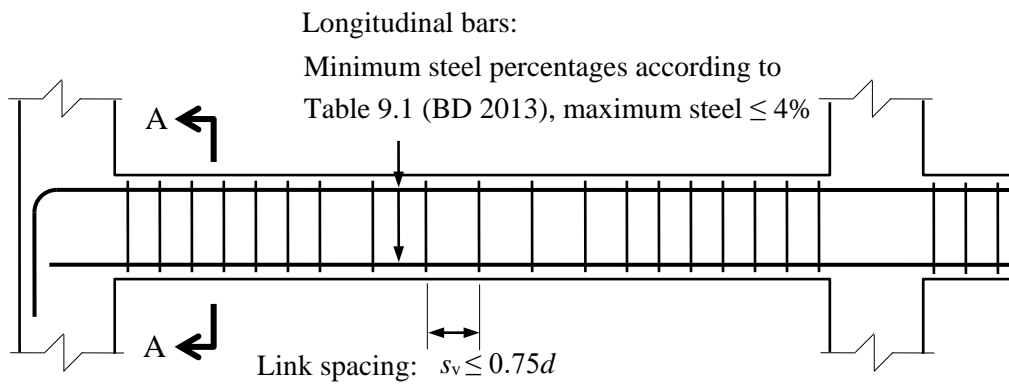
**Figure 2.6** Reinforcement requirements for conventional RC columns

## 2.6 Frame beams

The detailing provisions described below are applicable to conventional frame beams of normal proportions. Deep beams are not considered. For the design of deep beams, reference should be made to specialist literature. The detailing requirements of beams are summarised in **Table 2.5** and **Fig. 2.7**.

**Table 2.5.** Detailing requirements of conventional RC frame beams

Requirements	Clause No. (BD 2013)	Figure No.
<p><b>Longitudinal reinforcement:</b></p> <p>The minimum percentages of longitudinal reinforcement appropriate for various conditions of loading are given in Table 9.1 (clause 9.2.1.1) (BD 2013).</p> <p>The maximum percentages of longitudinal reinforcement should not exceed 4% of the gross cross-sectional area of the concrete (clause 9.2.1.3).</p> <p>At the laps, the sum of the diameter of all reinforcement bars in a particular layer should not exceed 40% of the breadth of the section at that location (clause 9.2.1.3).</p> <p>The maximum clear distance between adjacent bars in tension should not exceed <math>70,000 \beta_b / f_{yl} \leq 300</math> mm, where <math>\beta_b</math> and <math>f_{yl}</math> are the redistribution ratio and estimated service stress in the longitudinal reinforcement respectively, as defined in clause 9.2.1.4.</p>	9.2.1	2.7
<p><b>Transverse reinforcement:</b></p> <p>The maximum spacing of the links in the direction of the span should not exceed <math>0.75d</math>. At right-angles to the span, the horizontal spacing should be such that no longitudinal tension bar is more than 150 mm from a vertical leg.</p> <p>Links should be adequately anchored by means of 135°, 150° or 180° hooks. Where there is adequate confinement to prevent the end anchorage of the link from “kick off”, the 135° hook may be replaced by other standard anchorages.</p>	9.2.2 and 9.9.1.3	



Section A-A

**Figure 2.7** Reinforcement requirements for conventional RC frame beams



## 2.7 RC beam-column joints

The detailing provisions summarised in **Table 2.6** and **Figs. 2.8** and **2.9** are applicable to beam-column joints. In the detailing requirements, at least 50% of the shear resistance in the joint is provided by the reinforcement in the form of hoops to confine the concrete core. **A beam-column joint is considered to be restrained if the joint is laterally supported on four sides by beams of approximately equal depth. Any joint which is not part of the primary seismic force-resisting wall system need not satisfy the following provisions for joint detailing requirements.**

**Table 2.6.** Detailing requirements of beam-column joints

Requirements	Clause No. (BD 2013)	Figure No.
<p>Vertical joint shear reinforcement:</p> <p>Centre-to-centre spacing <math>s_{vj}</math> of the vertical joint shear reinforcement in either direction should not exceed 200 mm or one-quarter of the lateral dimension of the joint <math>b_j</math> in the orthogonal direction, whichever is the larger.</p> <p>Each vertical face of the joint should be provided with at least one vertical joint shear bar.</p> <p><b>Intermediate column bars at each side within the beam-column joint can act as vertical joint shear reinforcement.</b></p>	6.8.1.6	
<p>Horizontal transverse reinforcement:</p> <p>The diameter of the horizontal transverse reinforcement <math>\phi</math> should not be less than <b>8 mm</b> or one-quarter of the diameter of the largest column bar <math>\phi</math>, whichever is the greater.</p> <p>The spacing of transverse reinforcement <math>s_t</math> in the joint core should not exceed the least of the following:</p> <p>(a) ten times the diameter of the smallest column bar;</p> <p>(b) 200 mm</p> <p>(c) <b>one-quarter of the beam depth.</b></p> <p><b>At least 50% of the shear resistance provided by the reinforcement should be in the form of hoops. The remaining reinforcement could be in the form of crossties or U-bars with proper anchorages within the connecting beams.</b></p>	6.8.1.7	2.8
<p>Where there is adequate confinement to prevent the end anchorage of the link from “kick off”, the <b>135° or 180° hook</b> in the links or crossties may be replaced by a 90° hook.</p>	9.5.2.2	2.9

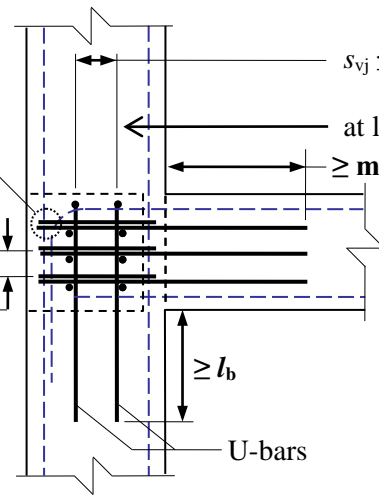
## Elevation

Horizontal transverse reinforcement:

At least 50% of the shear resistance is provided by links.

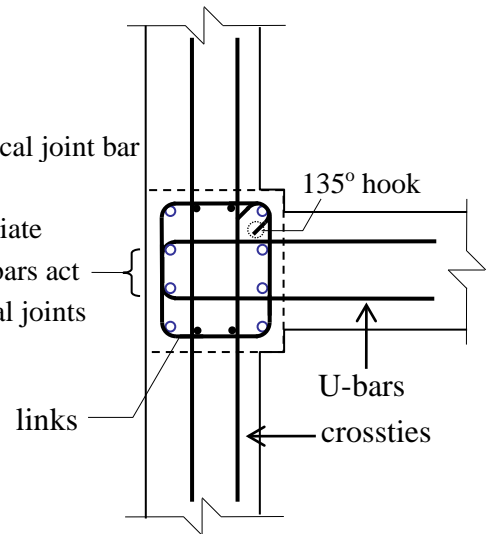
$$\phi \geq \begin{cases} \phi/4 \\ 8 \text{ mm} \end{cases}$$

$$s_t \leq \begin{cases} 10\phi_{l,\min} \\ 200 \text{ mm} \\ h/4 \end{cases}$$



## Section

Vertical joint bars:



$b_j$  – lateral joint dimension

$h$  – depth of beam

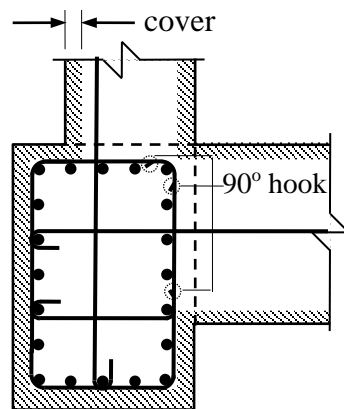
$\phi$  – diameter of column bars



$\phi$  – diameter of horizontal transverse reinforcement

$l_b$  – ultimate anchorage bond length

**Figure 2.8** Reinforcement requirements for beam-column joints

## Section



-  confined concrete. Links within this area may be anchored by 90° hooks.
-  unconfined concrete. Links within this area should be anchored by 135° or 180° hooks.

**Figure 2.9** Confined and unconfined concrete regions of a beam-column joint

## 2.8 References

- ACI 318 (2014). *Building Code Requirements for Structural Concrete (ACI 318-14) and Commentary*, ACI Committee 318, USA.
- ASCE (2002). *Minimum Design Loads for Buildings and Other Structures. ASCE 7-02*. American Society of Civil Engineers, Reston, VA.
- BD (2013). *Code of Practice for Structural Use of Concrete*, Buildings Department, The Government of the HKSAR.
- CTBUH (2008). *Recommendations for the Seismic Design of High-rise Buildings*, Council of Tall Buildings and Urban Habitat, Chicago, IL.
- Fanella DA (2007). *Seismic detailing of concrete buildings*, 2<sup>nd</sup> Edition, Portland Cement Association, Illinois, USA.
- Greifenhagen C and Lestuzzi P (2005). Static cyclic tests on lightly reinforced concrete shear walls, *Engineering Structures*, **27**(11), pp. 1703-1712.
- Hilson CW, Segura CL and Wallace JW (2014). Experimental study of longitudinal reinforcement buckling in reinforced concrete structural wall boundary elements. *Proceedings of the Tenth U.S. National Conference on Earthquake Engineering (10NCEE), Frontiers of Earthquake Engineering*. July 21-25, 2014 Anchorage, Alaska.
- Ho JCM (2003). *Inelastic Design of Reinforced Concrete Beams and Limited Ductile High-Strength Concrete Columns*, PhD Thesis, The University of Hong Kong, Hong Kong.
- Huang K (2003). *Design and Detailing of Diagonally Reinforced Interior Beam-Column Joints for Moderate Seismicity*, PhD Thesis, The University of Hong Kong, Hong Kong.
- Hube MA, Marihuén A, de la Llera JC and Stojadinovic B (2014). Seismic behavior of slender reinforced concrete walls. *Engineering Structures*, **80**, pp. 377-388.
- Kuang JS and Ho YB (2007). Enhancing ductility of non-seismically designed RC shear walls, *Proceedings of the Institution of Civil Engineers - Structures & Buildings*, **160** (SB3), pp. 139-149.
- Kuang JS and Ho YB (2008). Seismic behavior and ductility of squat RC shear walls with nonseismic detailing. *ACI Structural Journal*, **105**(2), pp. 225-231.
- Kuang JS and Wong HF (2005). Improving ductility of non-seismically designed RC columns, *Proceedings of the Institution of Civil Engineers - Structures and Buildings*, **158** (4), pp. 13-20.

Lam SSE, Wu B, Wong YL, Wang ZY, Liu ZQ and Li CS (2003). Drift capacity of rectangular reinforced concrete columns with low lateral confinement and high-axial load, *Journal of Structural Engineering ASCE*, **129**(6), pp. 733-741.

LATBSDC (2011). *An Alternative Procedure for Seismic Analysis and Design of Tall Buildings Located in the Los Angeles Region*, Los Angeles Tall Buildings Structural Design Council, USA.

Leung KT, Tse KL, Lau LS, Wong KH, Lee KH, Lam JYK, Zhang HY and Zhou XY (2016). Recent study on seismic evaluation of existing buildings – a Hong Kong Perspective, *Proceedings of the Joint Structural Division Annual Seminar 2016, Structural Excellence – From Research to Application*, The Hong Kong Institution of Engineers and The Institution of Structural Engineers, 12 January 2016, Hong Kong, pp35-67.

Li J (2003). *Effects of Diagonal Steel Bars on Performance of Interior Beam-Column Joints Constructed with High-Strength Concrete*, PhD Thesis, The University of Hong Kong, Hong Kong.

NRC (2010). *National Building Code of Canada (NBCC); Part 4: Structural design*, Canadian Commission on Building and Fire Codes, National Research Council of Canada (NRCC), Ottawa, Canada.

SRIA (2015). *Guide to Seismic Design and Detailing of Reinforced Concrete Buildings in Australia*, Steel Reinforcement Institute of Australia, Roseville, New South Wales, Australia.

Wong HF and Kuang JS (2008). Effects of beam-column depth ratio on joint seismic behaviour, *Proceedings of the Institution of Civil Engineers - Structures & Buildings*, **161** (SB2), pp. 91-101.

Xiong ZH (2001). *Reinforced Concrete Column Behaviour Under Cyclic Loading*, PhD Thesis, The University of Hong Kong, Hong Kong.

## 3 DUAL SYSTEMS

### 3.1 Scope

The detailing provisions described herein apply to RC buildings not taller than 300 m, with moment resisting frames together with structural walls acting as the primary earthquake force-resisting system. In this structural system, vertical loads are mainly supported by a spatial frame and lateral loads are resisted by the combined contribution of frames and walls (coupled, uncoupled or core). The main advantages of this structural system are that, first, frames interacting with walls can provide a significant amount of energy dissipation; second, the large lateral stiffness of walls can easily control the IDR demand; and, third, the development of a soft storey mechanism involving column hinges can be avoided.

Under occasional earthquake, the maximum BCR and IDR demands of frame-wall buildings (with or without transfer structures) should not be greater than 1.0% and 0.80% respectively.

Under rare earthquake, when no-collapse limit state is explicitly considered, the BCR and IDR demands of frame-wall buildings are increased to 2.0% and 1.5% respectively.

As the seismic IDR or DIDR demand of a dual structural system in a soil site is already very high, the use of a transfer structure is not recommended. If the use of a transfer structure is unavoidable, one should consider transferring the column loads rather than the wall loads as RC frames are considerably more deformable than structural walls and the shear localisation effect near the transfer structure is smaller for columns. When a transfer structure is utilised, the in-plane local rotations of the transfer structure due to gravity loads should be limited to 0.1%, and the DIDR should not exceed 0.80% under occasional earthquake events and 1.5% under rare earthquake actions.

The detailing provisions presented in this Chapter aim to provide sufficient drift ratio capacity for the RC members to cope with the aforementioned deformation demands.

Under extreme conditions, when the drift ratio demand of wall is higher than the anticipated deformation demand under rare earthquake load, drift ratio prediction formulas are given in **Section 3.8** to aid seismic detailing of rectangular walls.

### 3.2 Detailing considerations

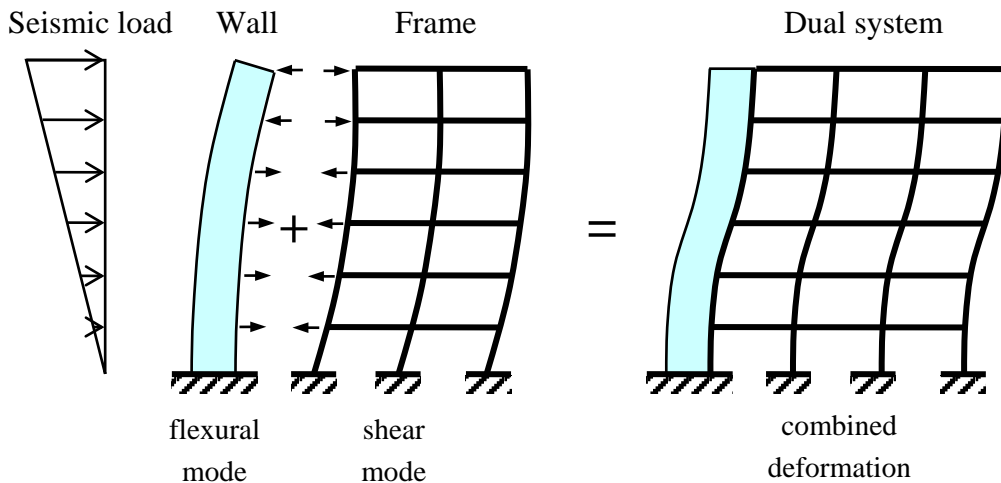
Under seismic action, a frame will deform primarily in a shear mode, whereas a wall will behave in the manner of a vertical cantilever with primary flexural deformations (see **Fig. 3.1**). Floor slabs usually act as a diaphragm, transmitting inertia forces generated by earthquake actions at a given level to all horizontal-force-resisting members. The slabs should be designed to respond elastically as they are ineffective at dissipating energy through the formation of plastic regions. The restraints provided by the slabs cause the frames and walls at each level to move together. The interaction of the two different

deformation modes leads to the walls and frames sharing the resistance of storey shears in the lower storeys, but tend to oppose each other at higher levels (see **Fig. 3.2**). The load distribution between frames and walls is strongly dependent on the dynamic response characteristics and the development of plastic hinges during a rare earthquake (Paulay and Priestley, 1992).

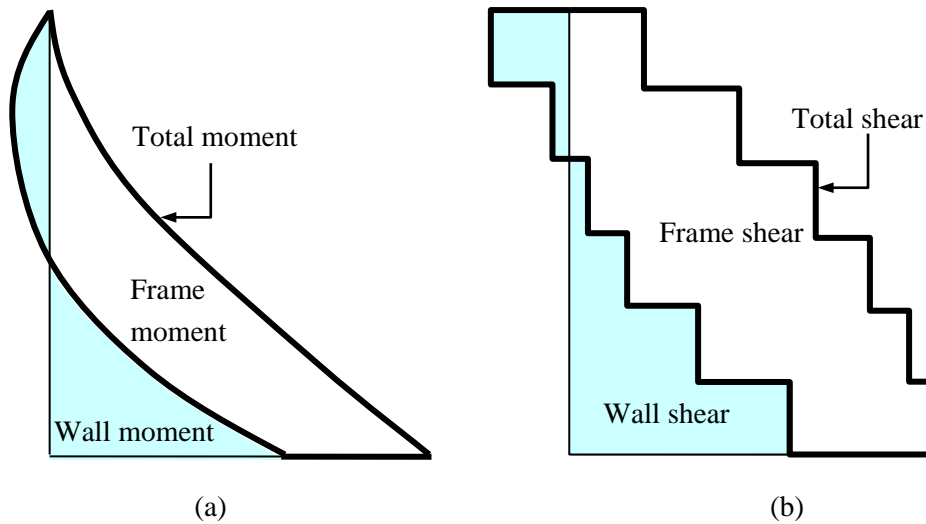
**Fig. 3.3** sets out some of the more preferable and practical energy-dissipating mechanisms for the dual system. For a building designed with a weak beam / strong column principle, as shown in **Fig. 3.3(a)**, plastic hinges are formed in all the beams and at the base of all vertical members. Thus the complicated construction of the lapping of vertical reinforcement at the middle height of columns in upper levels can be avoided. However, when long-span beams are used, the strength of beams is typically greater than that of columns, and as such it may be preferable to allow the development of plastic hinges at both ends of the columns (**Fig. 3.3(b)**).

The typically large stiffness variation between the frame and the wall implies that the wall yields at a lower lateral displacement than does the frame. The subsequent stiffness and strength degradations of the wall cause the redistribution of lateral force between the wall and frame as the lateral displacement increases. Hence, the proportion of base shear carried by the frame will be increased at the no-collapse limit state. The American Standard ASCE 07-10 (ASCE 2010) requires that the frames of the shear wall-frame interactive system should be capable of resisting at least 25% of the design storey shear of each storey.

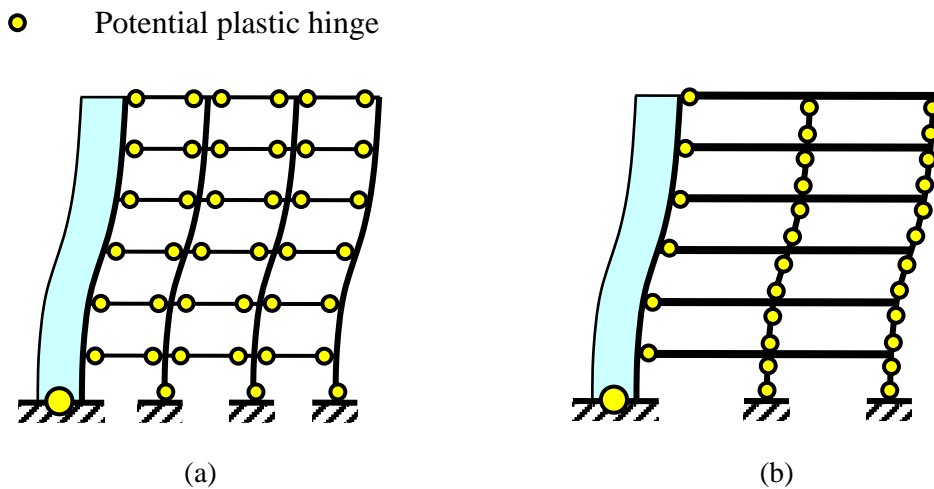
Dynamic analysis is recommended to evaluate the seismic response of a building. When the predicted maximum IDR demand is higher than 1% in the no-collapse limit state, the structural response should be evaluated using non-linear time history analysis.



**Figure 3.1** Interaction of a frame-wall system under seismic loads



**Figure 3.2** Internal force distributions in wall and frame (a) overturning moment and (b) storey shear



**Figure 3.3** Preferable energy dissipating mechanisms for dual system with a (a) weak beam / strong column arrangement and (b) strong beam / weak column arrangement

Despite the strength design, appropriate seismic details should be provided to enhance the deformability of structural walls. The drift capacity of structural walls primarily depends on the failure mode, the SDR, the ALR and the reinforcement arrangements. In order to ensure a wall will have sufficient deformability against rare earthquake loads, brittle shear failures should be avoided when conducting no-collapse limit state checks. In other words, the seismic shear capacity of walls should be higher than the seismic shear demand associated with rare earthquake loads. When plastic hinges are expected to form in walls during an earthquake attack, the shear capacity of the walls should be higher than the corresponding flexural capacity, so as to promote a flexural ductile failure mechanism.

### 3.3 Structural walls

The detailing provisions described here refer to ductile RC walls with a length to thickness ratio of 4 or more and in which the section and reinforcement have been designed to resist seismic forces.

The ALR should not exceed 0.1. Such a small ALR can enhance drift capacity and minimise the potential risk of the compression failure of walls under severe earthquake loads.

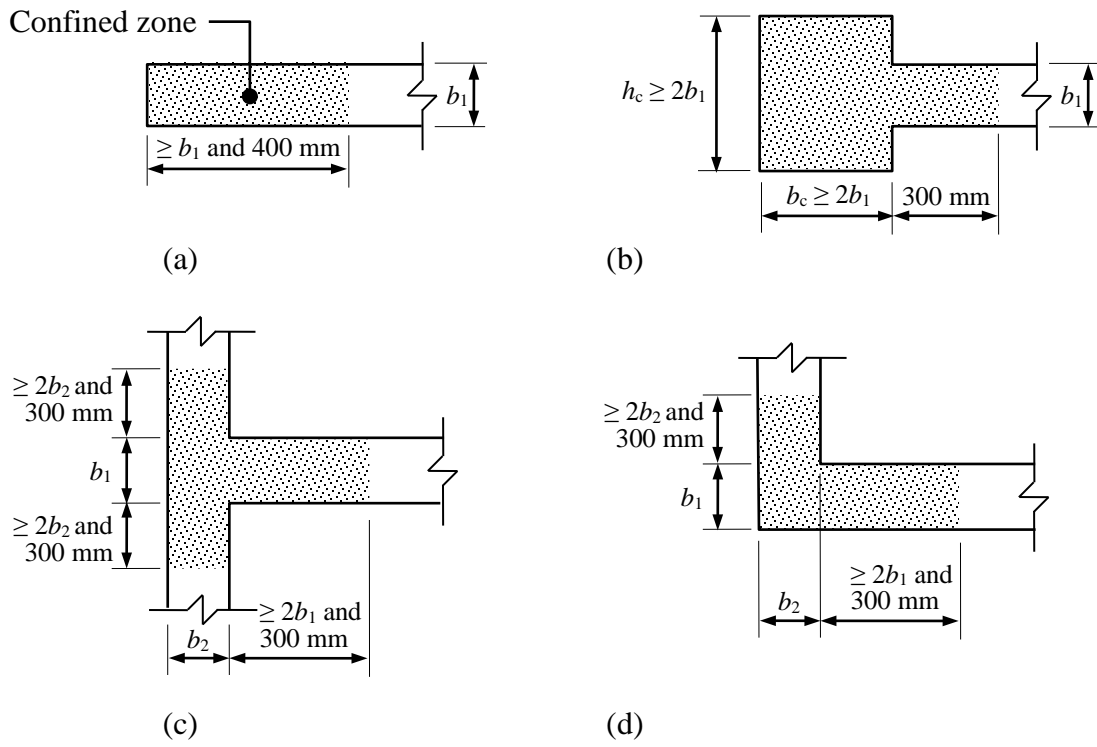
The extent of confined boundary elements of ductile RC walls is defined in **Fig. 3.4**. The vertical, horizontal and transverse detailing requirements for ductile RC walls are summarised in **Table 3.1** and **Fig. 3.5**. Reinforcement provided for shear strength should be continuous and uniformly distributed across the shear plane. The uniform distribution of reinforcement across the height and horizontal length of the wall helps control the width of inclined cracks. For walls subjected to substantial in-plane shear forces, two layers of reinforcement should be provided in order to reduce the fragmentation and premature deterioration of the concrete under load reversals into the inelastic range (Fanella, 2007).

**Table 3.1.** Detailing requirements for ductile RC walls

Requirements	Clause No. (BD 2013)	Figure No.
<p><b><u>Shear span-to-depth ratio</u></b></p> <p><b>The shear span-to-depth ratio should not be less than 2.0.</b></p>	N.A.	N.A.
<p><b><u>Axial compression ratio</u></b></p> <p><b>The axial compression ratio <math>N_{cr}</math> should not exceed 0.325.</b></p>	N.A.	N.A.
<p><b><u>Confined boundary elements</u></b></p> <p>The extent of this confined boundary element is illustrated in <b>Fig. 3.4</b>.</p> <p>This confined boundary element should be provided with vertical reinforcement satisfying the following requirements (<b>Fig. 3.5</b>):</p> <ol style="list-style-type: none"> <li>(1) <math>\rho_l</math> should not be less than 1% of the sectional area of the structural boundary element;</li> <li>(2) <b><math>\rho_l</math> should not be more than 2%;</b></li> <li>(3) <math>\phi_l</math> should not be smaller than 16 mm and the number of bars should not be less than six;</li> <li>(4) spacing <math>s_1</math> should not exceed 150 mm;</li> <li>(5) each vertical bar should be tied with links <b>or ties</b> of at least 12 mm diameter, and vertical spacing should not exceed 150 mm; and</li> <li>(6) <b>links and ties should be adequately anchored by means of 135° hooks. Where there is adequate confinement to prevent the end anchorage of the link from “kick off”, the 135° hook may be replaced by other standard hooks.</b></li> </ol>	9.9.3.2	3.4 and 3.5

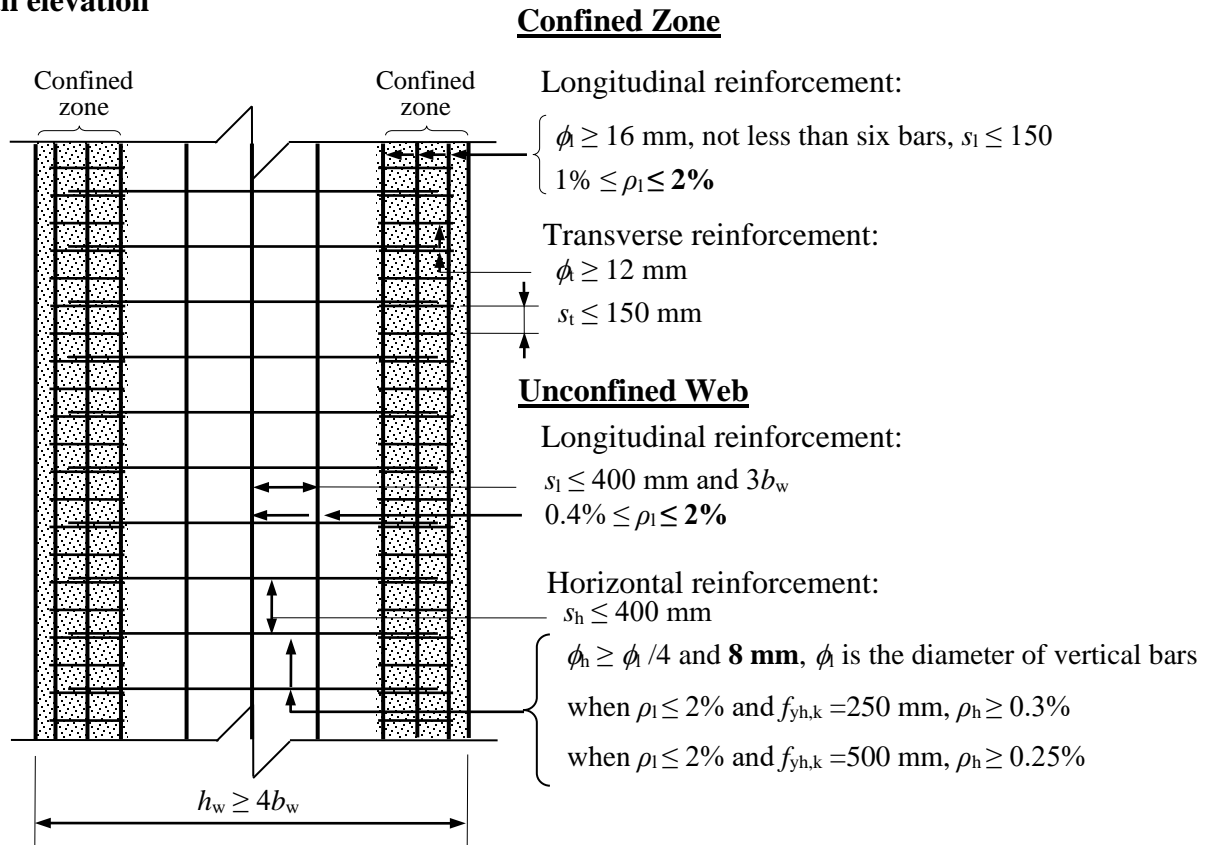


<p><u>Unconfined web</u></p> <p>Vertical reinforcement:</p> <p>The minimum and maximum percentages of vertical reinforcement <math>\rho_l</math> based on the concrete cross-sectional area of a wall are 0.4% and <b>2%</b> respectively.</p> <p><b>Two layers of vertical reinforcement are recommended.</b></p> <p>Vertical bar spacing <math>s_l</math> shall not exceed three times the wall thickness <math>b_w</math> or 400 mm, whichever is the lesser.</p>	9.6.2	
<p>Horizontal reinforcement:</p> <p>Where the main vertical reinforcement is used to resist compression and does not exceed 2% of the concrete area, at least the following percentages of horizontal reinforcement <math>\rho_h</math> should be provided:</p> <p>(a) <math>f_{yh,k} = 250 \text{ N/mm}^2</math>: 0.30% of concrete cross-sectional area; and  (b) <math>f_{yh,k} = 500 \text{ N/mm}^2</math>: 0.25% of concrete cross-sectional area.</p> <p>Reinforcement spacing <math>s_h</math> should be evenly spaced at no more than 400 mm. The diameter <math>\phi_h</math> should be not less than one-quarter of the size of the vertical bars <math>\phi_l</math> and not less than <b>8 mm</b>.</p>	9.6.3	3.5
<p>Transverse reinforcement:</p> <p>When the vertical compression reinforcement exceeds 2%, links with a diameter of <math>\phi_l</math> and at least <b>8 mm</b> or one-quarter the size of the largest compression bar should be provided through the thickness of the wall.</p> <p>The spacing of links <math>s_t</math> should not exceed twice the wall thickness <math>b_w</math> in either the horizontal or vertical direction.</p> <p>In the vertical direction, it should be not greater than 16 times the bar diameter <math>\phi_l</math>.</p> <p>All vertical compression bars should be enclosed by a link.</p> <p>No bar should be further than 200 mm from a restrained bar, at which a link passes round the bar at an included angle of not more than <math>90^\circ</math>.</p>	9.6.4	

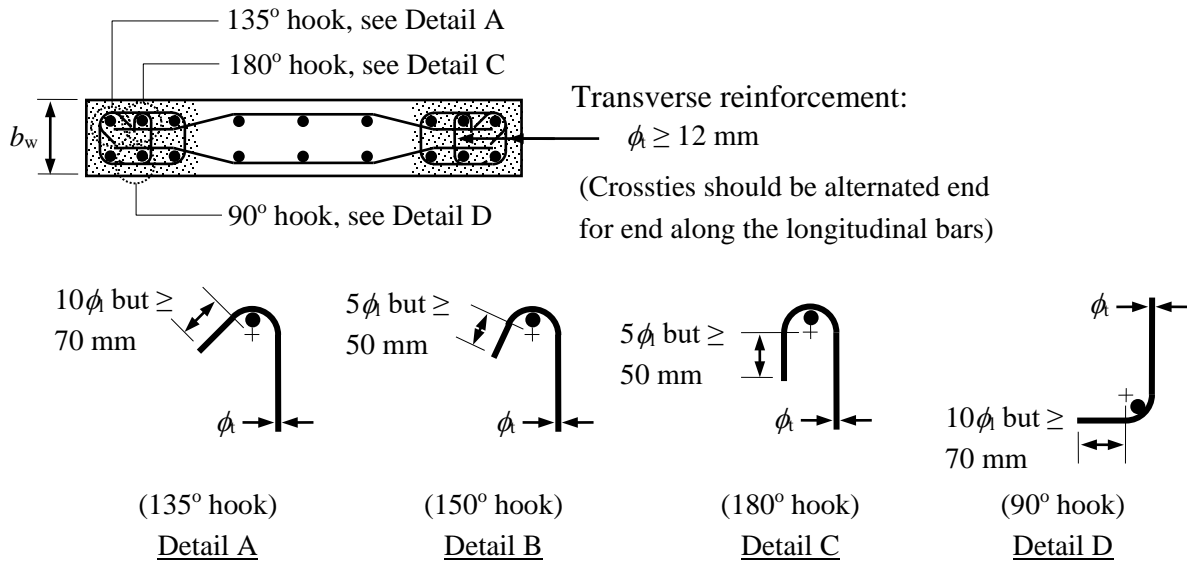


**Figure 3.4** Confined boundary elements (a) hidden column, (b) edge column, (c) wing wall and (d) L-shaped wall

## Wall elevation



## Wall sections



**Figure 3.5** Reinforcement requirements for ductile RC walls

### 3.4 Ductile coupling beams

Coupling beams are used to connect shear walls with openings such as windows, corridors and stairs. Their span-to-depth ratios are usually smaller than 4. They are subjected to moments and shears under seismic actions in the plane of the wall. According to the predicted seismic demand of buildings with dual structural systems in Hong Kong during a rare earthquake, the maximum chord rotation demand of coupling beams is 2.0%, which implies that those coupling beams have been yielded. In order to avoid complicated diagonal reinforcement, only the RC detailing provisions of orthogonal RC ductile coupling beams are presented (in **Table 3.2** and **Fig. 3.6**) in this Guide. The interested reader may refer to Moehle et al. (2012) for details of diagonally reinforced coupling beams.

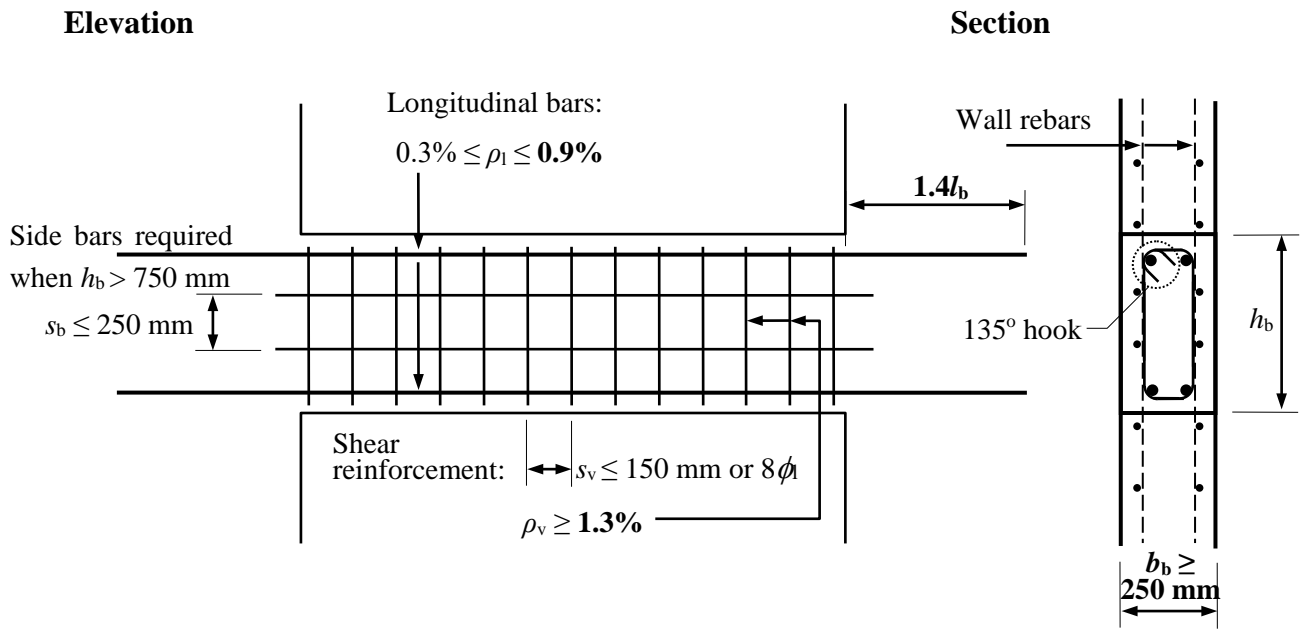
The Hong Kong Code of Practice for Structural Use of Concrete 2013 (BD, 2013) does not separately provide detailing provisions for floor beams and coupling beams. As plastic hinges will potentially form at the beam ends and the size of the plastic hinges may extend over almost the entire length of the beam, this Guide adopts the ductile requirements of the critical region of RC floor beams for ductile coupling beams.

The ultimate chord rotation capacity of RC coupling beams primarily depends on the mode of failure, the SDR, the shear and the longitudinal reinforcement percentages. To ensure the coupling beams have high rotational capacity without premature brittle failure, the shear capacity of the beams should be designed to be higher than their flexural capacity. To achieve the required rotational capacity using orthogonal RC coupling beams, the available test results demonstrate that the following design conditions should be met simultaneously: (1)  $SDR \geq 0.85$ , (2) shear reinforcement area ratio  $\rho_v \geq 1.3\%$ , (3) longitudinal reinforcement area ratio  $\rho_l \leq 0.9\%$  and (4) characteristic concrete cube compressive strength  $f_{cu,k} \geq 30$  MPa (or the expected concrete cube compressive strength  $f_{cu,m} \geq 45$  MPa). In addition, the thickness of the coupling beams should be at least 250 mm so as to allow wall and beam reinforcement to be properly fixed and the concrete placed (SRIA, 2015).

**Table 3.2.** Ductile coupling beam detailing requirements

Requirements	Clause No. (BD 2013)	Figure No.
<p><b><u>Shear span-to-depth ratio</u></b></p> <p><b>The <math>SDR = M/(V \times h_b)</math> should not be less than 0.85.</b></p>	N.A.	N.A.
<p>Longitudinal reinforcement:</p> <p>The minimum and <b>maximum percentages</b> of longitudinal reinforcement <math>\rho_l</math> based on the concrete cross-sectional area of a coupling beam are 0.3% and <b>0.9%</b> respectively (clause 9.9.1.2).</p> <p>The clear horizontal distance between adjacent longitudinal bars should not exceed <math>70,000 \beta_b / f_{yl} \leq 300</math> mm, where <math>\beta_b</math> and <math>f_{yl}</math> are the redistribution ratio and estimated service stress in the longitudinal reinforcement respectively, as defined in clause 9.2.1.4.</p> <p><b>Curtailment of the longitudinal reinforcement is not recommended.</b></p> <p><b>The minimum anchorage length is recommended to be <math>1.4 l_b</math>, where <math>l_b</math> is the ultimate anchorage bond length.</b></p>	9.2.1.4 and 9.9.1.2	3.6
Shear reinforcement:	8.5, 9.2.2 and	

<p><b>The minimum percentage of shear reinforcement <math>\rho_v</math> based on the concrete horizontal-sectional area of a coupling beam is 1.3%.</b></p> <p>The centre-to-centre spacing of links <math>s_v</math> along a beam shall not exceed the larger of 150 mm or eight times the longitudinal bar diameter <math>\phi</math> (clause 9.9.1.3).</p> <p>At right-angles to the span, the horizontal spacing should be such that no longitudinal tension bar is more than 150 mm from a vertical leg (clause 9.2.2).</p> <p>Links should be adequately anchored by means of 135°, 150° or 180° hooks, in accordance with clause 8.5.</p>	9.9.1.3	
<p>Side bars for beams exceeding 750 mm overall depth:</p> <p>The minimum diameter of the bars must be <math>\geq \sqrt{(s_b b_b / f_{yw,k})}</math>, where <math>s_b \leq 250</math> mm is the bar spacing, <math>b_b</math> is the beam width, or 500 mm if <math>b_b</math> exceeds 500 mm, and <math>f_{yw,k}</math> is the characteristic yield strength of the side bar.</p>	9.2.1.2	



**Figure 3.6** Reinforcement requirements of ductile coupling beams

### 3.5 Ductile columns

The ultimate drift ratio of RC columns primarily depends on the mode of failure, the ALR, the SDR and the transverse reinforcement percentage. In order to ensure that the ultimate drift ratio capacity can reach 2.0%, the SDR should not be less than 2.0 and sufficient transverse reinforcement should be provided to avoid brittle shear failure prior to ductile flexural failure. In this Guide, the location of potential plastic hinges is denoted as a critical zone. Laps of longitudinal reinforcement should be located away from the critical zones. The detailing provisions for the seismic design of ductile columns for which the larger dimension  $h_c$  is not greater than four times the smaller dimension  $b_c$  are summarised in **Table 3.3** and **Figs. 3.7**.

**Table 3.3.** Detailing requirements of ductile columns

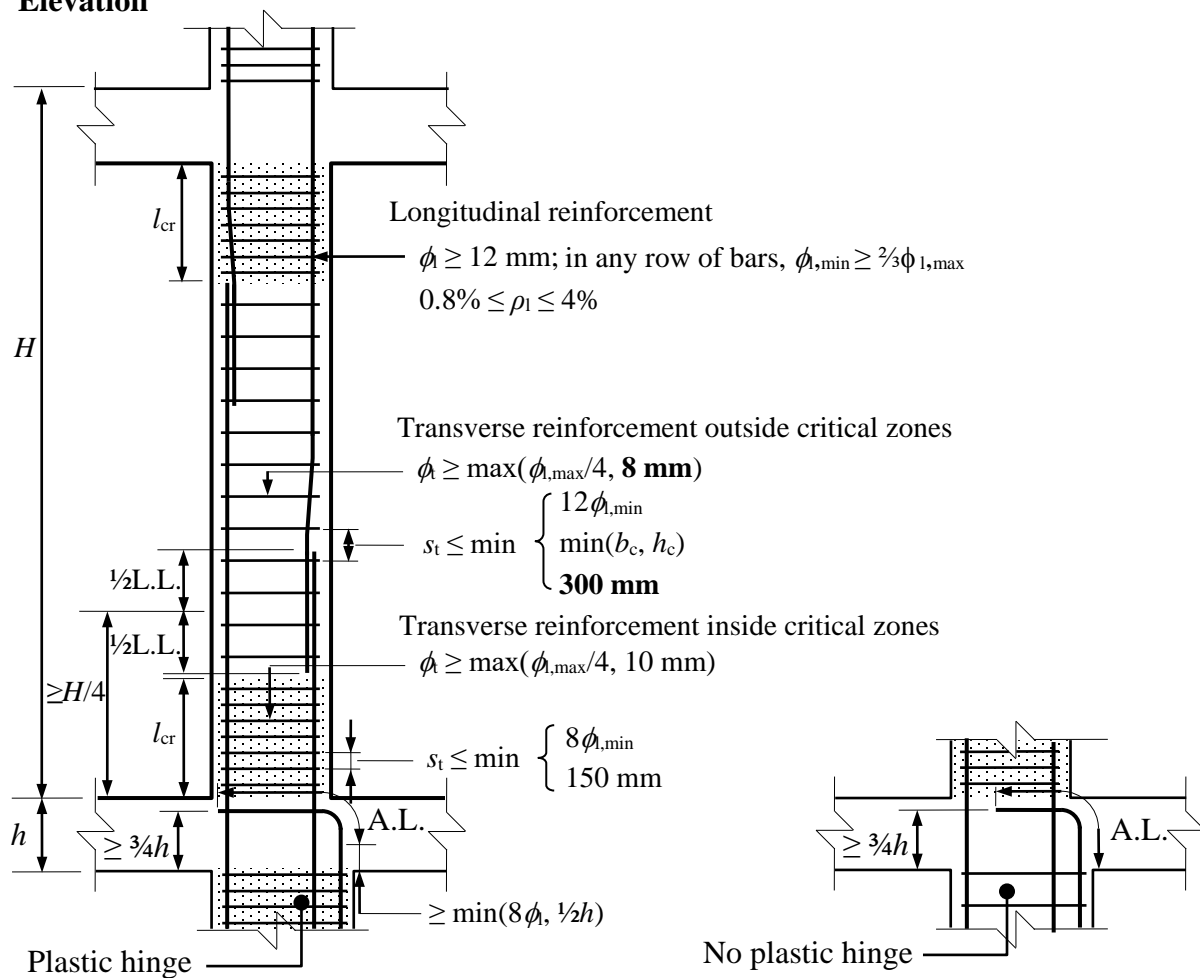
Requirements	Clause No. (BD 2013)	Figure No.
<p><b><u>Shear span-to-depth ratio</u></b></p> <p><b>The shear span-to-depth ratio of columns, which is defined as <math>M/(V \times h_c)</math>, should not be less than 2.0.</b></p>	N.A.	N.A.
<p>Longitudinal reinforcement:</p> <p>The minimum and maximum percentages of longitudinal reinforcement <math>\rho_l</math> based on the concrete cross-sectional area of a vertically-cast column are 0.8% and 4.0% respectively. At the laps, the reinforcement percentage may be increased to 5.2%. Furthermore, the sum of the reinforcement sizes in a particular layer of laps should not exceed 40% of the breadth of the section at that location.</p> <p>In any row of bars, the smallest bar diameter used should not be less than two thirds of the largest bar diameter used.</p> <p>The smallest bar diameter <math>\phi</math> should not be less than 12 mm.</p> <p>The minimum number of longitudinal bars in a column should be four in rectangular columns and six in circular columns. In columns with a polygonal cross-section, at least one bar should be placed at each corner.</p> <p>For longitudinal bars in potential plastic hinge regions, the restrained (cross-linked) bars should not be spaced further apart between centres than the larger of one-quarter of the adjacent lateral column dimension or 200 mm.</p> <p>Where column bars terminate in beam-column joints or joints between columns and foundation members, and where a plastic hinge in the column may be expected, the anchorage of the longitudinal column bars into the joint region should be assumed to commence at one-half of the depth of the beam or eight bar diameters <math>\phi</math>, whichever is less, from the face at which the column bar enters the beam or foundation member. When it is shown that a column plastic hinge adjacent to a beam face cannot occur, the development length should be considered to commence from the beam face.</p> <p>Column bars should be terminated in a joint area with a horizontal 90° standard hook or equivalent anchorage device as close to the far face of the beam as practicably possible, and not closer than three-quarters of the depth of the beam to the face of entry. Unless a column is designed to resist only axial forces, the direction of the horizontal leg of the bend must always be positioned towards the far face of the column.</p>	9.5.1 and 9.9.2.1	3.7
<p>Critical zone:</p> <p>The extent of a critical zone <math>l_{cr}</math> in columns should commence from the point of maximum moment over a finite length suggested as follows (including the zone influenced by the stub effect):</p> <p>For <math>0 &lt; N/(A_g f_{cu,k}) \leq 0.1</math>, the extent of a critical zone is taken as 1.0</p>	9.9.2.2	N.A.

<p>times the greater dimension of the cross-section or where the moment exceeds 0.85 of the maximum moment or one-sixth of the column clear height at the floor, whichever is larger, where <math>A_g</math> is the gross area of section, <math>\text{mm}^2</math>.</p> <p>For <math>0.1 &lt; N/(A_g f_{cu,k}) \leq 0.3</math>, the extent of a critical zone is taken as 1.5 times the greater dimension of the cross-section or where the moment exceeds 0.75 of the maximum moment or one-sixth of the column clear height at the floor, whichever is larger; and</p> <p>For <math>0.3 &lt; N/(A_g f_{cu,k}) \leq 0.6</math>, the extent of a critical zone is taken as 2.0 times the greater dimension of the cross-section or where the moment exceeds 0.65 of the maximum moment or one-sixth of the column clear height at the floor, whichever is larger.</p>		
<p>Transverse reinforcement inside critical zones:</p> <p>The diameter of the transverse reinforcement <math>\phi_t</math> should not be less than 10 mm or one-quarter of the diameter of the largest longitudinal bar <math>\phi_{l,max}</math>, whichever is the greater.</p> <p>For rectangular or polygonal columns, the centre-to-centre spacing of links or cross-ties <math>s_t</math> along a column should not exceed the smaller of eight times the diameter of the longitudinal bar <math>\phi</math> to be restrained or 150 mm. The arrangement of links or ties within the cross section should comply with either one of the following requirements:</p> <ul style="list-style-type: none"> <li>(i) each longitudinal bar or bundle of bars should be laterally supported by a link passing around the bar, or</li> <li>(ii) every corner bar and each alternate longitudinal bar (or bundle) in the outer layer of reinforcement should be supported by a link passing around the bar, and no bar within the compression zone should be further than the smaller of ten times the diameter of link <math>\phi_t</math> or 125 mm from a restrained bar.</li> </ul> <p>For circular columns, the centre-to-centre spacing of spirals or circular hoops along the column should not exceed the smaller of eight times the diameter <math>\phi</math> of the longitudinal bar to be restrained or 150 mm.</p> <p>Links and ties should be adequately anchored by means of <math>135^\circ</math> hooks. Where there is adequate confinement to prevent the end anchorage of the link from “kick off”, the <math>135^\circ</math> hook may be replaced by other standard hooks.</p>	<p>9.9.2.2</p>	<p>3.7</p>
<p>Transverse reinforcement outside critical zones:</p> <p>The diameter of the transverse reinforcement <math>\phi_t</math> should not be less than <b>8 mm</b> or one-quarter of the diameter of the largest longitudinal bar <math>\phi_l</math>, whichever is the greater.</p> <p>The spacing of transverse reinforcement <math>s_t</math> along a column should not exceed the least of the following:</p> <ul style="list-style-type: none"> <li>(i) 12 times the diameter of the smallest longitudinal bar;</li> <li>(ii) the lesser dimension of the column;</li> <li>(iii) <b>300 mm</b>.</li> </ul> <p>For rectangular or polygonal columns, all corner bars and alternate</p>	<p>9.5.2.2 and 9.5.2.3</p>	

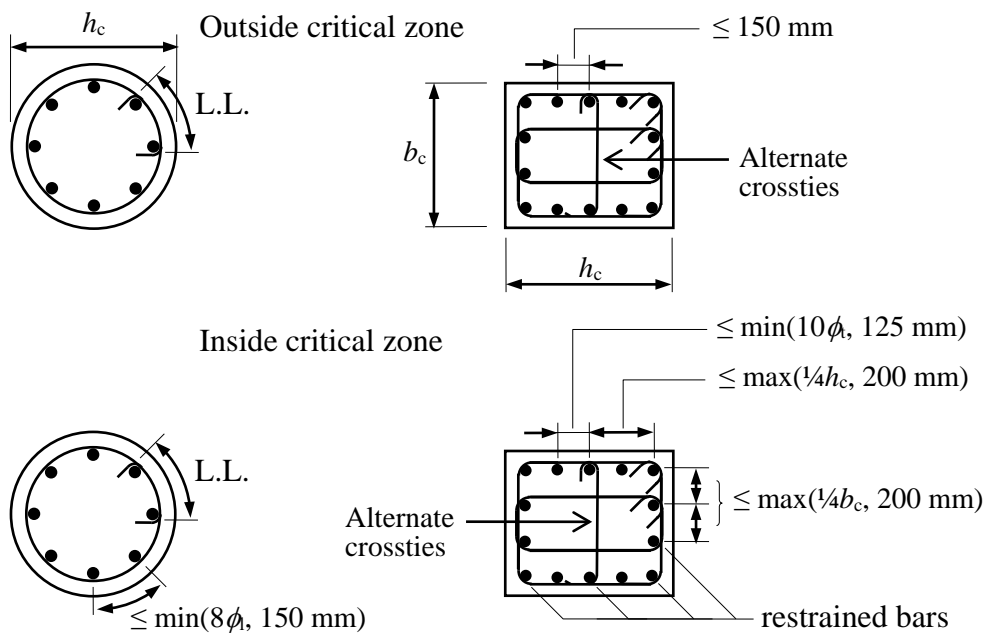
<p>bars (or bundles) in an outer layer of reinforcement should be supported by links, with or without crossies, passing around the bars and having an inclined angle of not more than 135°. No bar within a compression zone should be further than 150 mm from a restrained bar.</p> <p>For circular columns, spiral transverse reinforcement should be anchored by either being welded to the previous turn, in accordance with clause 8.7, or terminating the spiral with at least a 90° hook bent around a longitudinal bar and the hook being no more than 25 mm from the previous turn.</p> <p>For rectangular or polygonal columns, links should be adequately anchored by means of hooks bent through an angle of not less than 135°. Crossies should be adequately anchored by means of hooks bent through an angle of not less than 135° at one end and 90° at the other end, and should be alternated end for end along the longitudinal bars.</p> <p>For circular columns, circular links should be anchored by either a mechanical connection or a welded lap, in accordance with clause 8.7, or by terminating each end of the link with at least a 90° hook bent around a longitudinal bar and overlapping the other end of the link. Spiral or circular links should not be anchored by straight lapping.</p>		
---	--	--



**Elevation**



**Section**



L.L. – Lap length; A.L. – Anchorage length

**Figure 3.7** Reinforcement requirements of ductile columns

### 3.6 Ductile frame beams

The detailing provisions described below are applicable to ductile frame beams of normal proportions with an expected ultimate chord rotation of not less than 2.0%. Deep beams are not considered. For the design of deep beams, reference should be made to specialist literature. The location of the potential plastic hinges is denoted as the critical zone. Laps of reinforcement should be located away from the critical zones. The detailing requirements of ductile beams are summarised in **Table 3.4** and **Figs. 3.8** and **3.9**.

**Table 3.4.** Detailing requirements of ductile frame beams

Requirements	Clause No. (BD 2013)	Figure No.
<p>Critical zones:</p> <p>The critical zone is equal to two times the beam depth extending from the column face.</p>	9.9.1.1	3.8
<p>Longitudinal reinforcement inside the critical zone:</p> <p>The minimum percentages of longitudinal reinforcement appropriate for various conditions of loading are given in Table 9.1 (clause 9.2.1.1) and should not be less than 0.3% (clause 9.9.1.2) (BD 2013).</p> <p>The maximum percentages of tension reinforcement should not exceed <b>4%</b> of the gross cross-sectional area of the concrete (clause 9.9.1.2).</p> <p><b>The minimum percentages of compression reinforcement should not be less than 0.35 of tension reinforcement at the same section.</b></p> <p>The maximum clear distance between adjacent bars in tension should not exceed <math>70,000 \beta_b / f_{yl} \leq 300</math> mm, where <math>\beta_b</math> and <math>f_{yl}</math> are the redistribution ratio and estimated service stress in the longitudinal reinforcement respectively, as defined in clause 9.2.1.4.</p> <p>When longitudinal beam bars are anchored in cores of exterior columns or beam stubs, the tension anchorage should be deemed to commence at one-half of the relevant column depth or eight times the bar diameter <math>\phi</math>, whichever is less, from the face at which the beam bar enters the column. Where it can be shown that the critical section of the plastic hinge is at a distance of at least the beam depth or 500 mm, whichever is less, from the column face, the anchorage length may be considered to commence at the column face (clause 9.9.1.2).</p> <p>No bar should be terminated without a vertical 90° standard hook or equivalent anchorage device as close as practicably possible to the far side of the column core, or the end of the beam stub where appropriate, and not closer than three-quarters of the relevant column depth to the face of entry (clause 9.9.1.2).</p> <p>Top beam bars should only be bent down and bottom bars be bent up (clause 9.9.1.2).</p>	9.2.1.1, 9.2.1.4 and 9.9.1.2	3.8
<p>Longitudinal reinforcement outside the critical zone:</p> <p>The minimum percentages of longitudinal reinforcement appropriate for various conditions of loading are given in Table 9.1 (clause</p>	9.2.1.1, 9.2.1.3, 9.2.1.4 and 9.9.1.2	3.8

<p>9.2.1.1) (BD 2013).</p> <p>The maximum percentages of longitudinal reinforcement should not exceed 4% of the gross cross-sectional area of the concrete (clause 9.2.1.3).</p> <p>At the laps, the sum of the diameter of all reinforcement bars in a particular layer should not exceed 40% of the breadth of the section at that location (clause 9.2.1.3).</p> <p>The maximum clear distance between adjacent bars in tension should not exceed <math>70,000 \beta_b / f_{yl} \leq 300</math> mm, where <math>\beta_b</math> and <math>f_{yl}</math> are the redistribution ratio and estimated service stress in the longitudinal reinforcement respectively, as defined in clause 9.2.1.4.</p>		
<p>Transverse reinforcement inside the critical zone:</p> <p>The maximum spacing of the links in the direction of the span should not exceed <math>0.75d</math> (clause 9.2.2) and the larger of 150 mm or eight times the smallest diameter of the longitudinal bars <math>\phi_{,min}</math> (clause 9.9.1.3).</p> <p>Links or ties should be arranged so that every corner and alternate compression longitudinal bar should be restrained by a leg (clause 9.9.1.3).</p> <p>At right-angles to the span, the horizontal spacing of legs should not exceed the smaller of 20 times the diameter of the link <math>\phi</math> or 250 mm (clause 9.9.1.3).</p> <p>Furthermore, no longitudinal tension bar should be located more than 150 mm from a vertical leg (clause 9.2.2).</p> <p>Links should be adequately anchored by means of <math>135^\circ</math>, <math>150^\circ</math> or <math>180^\circ</math> hooks. Where there is adequate confinement to prevent the end anchorage of the link from “kick off”, the <math>135^\circ</math> hook may be replaced by other standard anchorages (<b>Fig. 3.9</b>), as mentioned in clause 9.9.1.3.</p>	<p>9.9.1.3 and 9.2.2</p>	<p>3.8 and 3.9</p>
<p>Transverse reinforcement outside the critical zone:</p> <p>The maximum spacing of the links in the direction of the span should not exceed <math>0.75d</math> (clause 9.2.2), the smaller of the least lateral dimension of the cross section of the beam or 12 times the smallest bar diameter of the longitudinal bars <math>\phi_{,min}</math> (clause 9.9.1.3).</p> <p>Links or ties should be arranged so that every corner and alternate compression longitudinal bar should be restrained by a leg (clause 9.9.1.3).</p> <p>At right-angles to the span, no longitudinal tension bar should be more than 150 mm from a vertical leg (clause 9.2.2).</p> <p>Links should be adequately anchored by means of <math>135^\circ</math>, <math>150^\circ</math> or <math>180^\circ</math> hooks. Where there is adequate confinement to prevent the end anchorage of the link from “kick off”, the <math>135^\circ</math> hook may be replaced by other standard anchorages (<b>Fig. 3.9</b>), as mentioned in clause 9.9.1.3.</p>	<p>9.9.1.3 and 9.2.2</p>	

**Inside the critical zone**

Longitudinal bars:

Min. steel according to Table 9.1 and  $\geq 0.3\%$ ,

Max. tension steel  $\leq 4\%$ ,

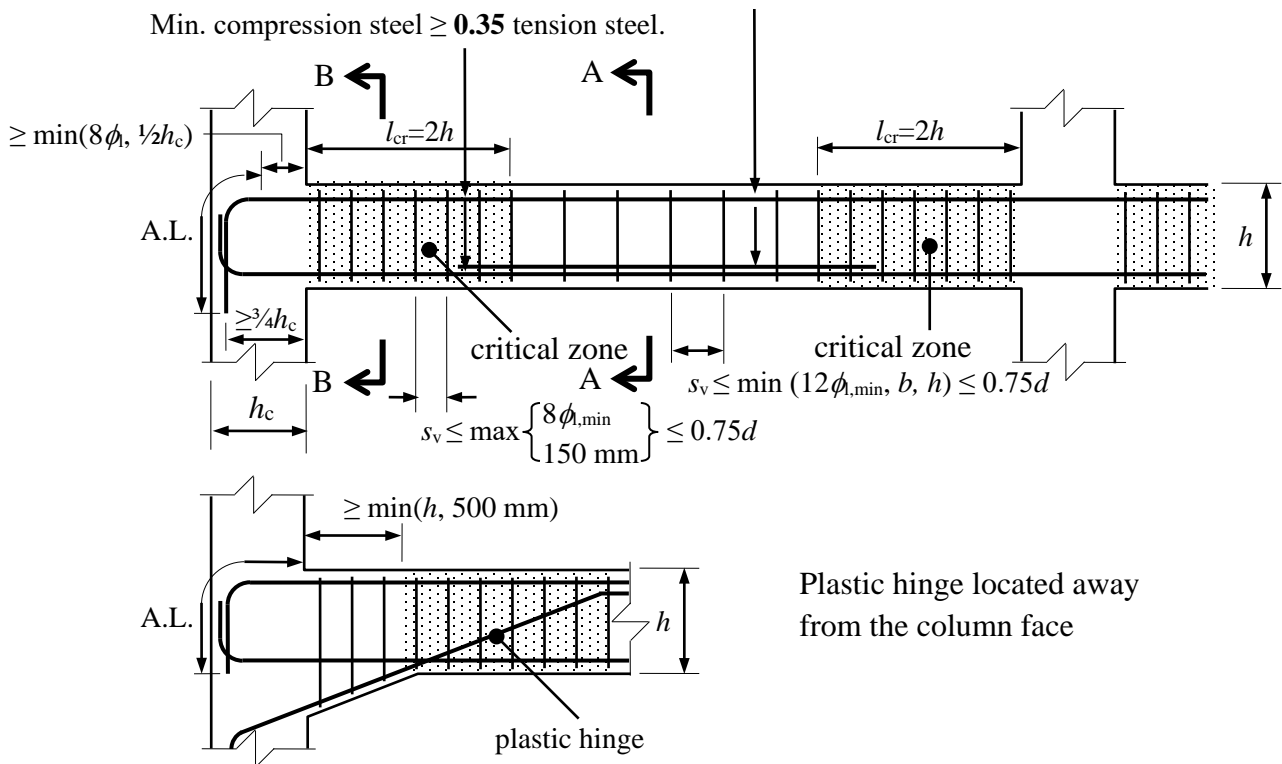
Min. compression steel  $\geq 0.35$  tension steel.

**Outside the critical zone**

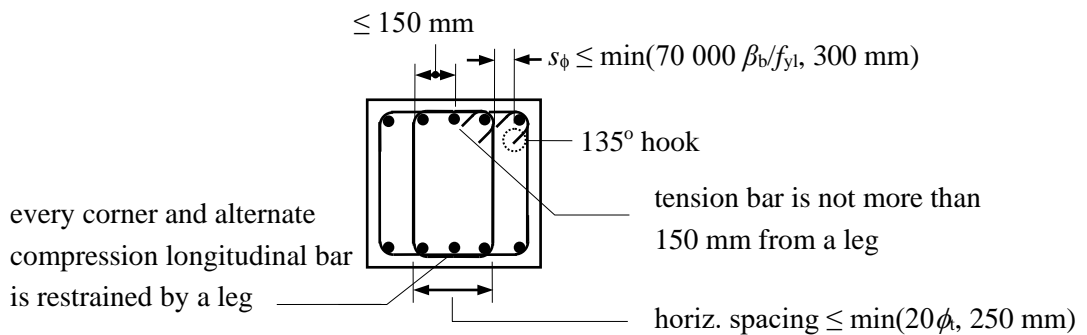
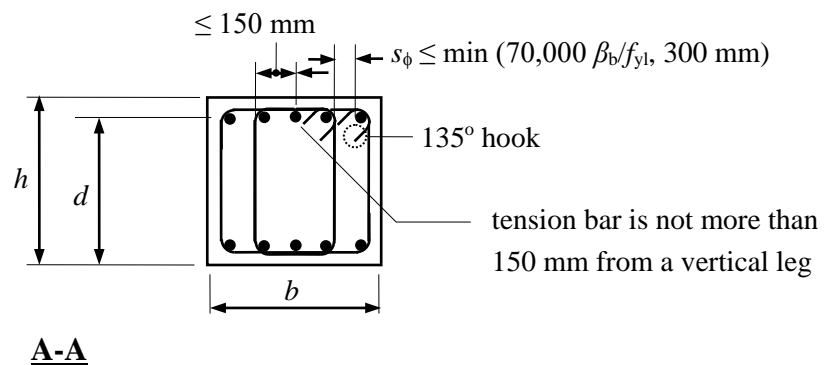
Longitudinal bars:

Min. steel according to Table 9.1 and  $\geq 0.3\%$ ,

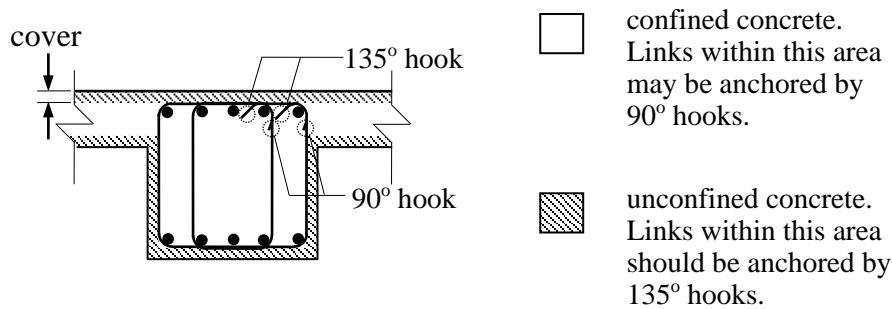
Max. tension steel  $\leq 4\%$ .



A.L. – Anchorage Length



**Figure 3.8** Reinforcement requirements for ductile frame beams



**Figure 3.9** Reinforcement requirements for beams confined with slabs

### 3.7 RC beam-column joints

The seismic design of beam-column joints should satisfy the following criteria, in accordance with clause 6.8.1.1:

- (a) at serviceability limit state, a joint should perform at least as well as the members that it joins; and
- (b) at ultimate limit state, a joint should have a design strength sufficient to resist the most adverse load combinations sustained by the adjoining members.

The detailing provisions summarised in **Table 3.5** and **Figs. 3.10** and **3.11** are applicable to beam-column joints.

**Table 3.5.** Detailing requirements of beam-column joints (same as **Table 2.6**)

Requirements	Clause No. (BD 2013)	Figure No.
<p>Vertical joint shear reinforcement:</p> <p>The centre-to-centre spacing <math>s_{vj}</math> of the vertical joint shear reinforcement in either direction should not exceed 200 mm or one-quarter of the lateral dimension of the joint <math>b_j</math> in the orthogonal direction, whichever is the larger.</p> <p>Each vertical face of the joint should be provided with at least one vertical joint shear bar.</p> <p><b>An intermediate column bar at each side within the beam-column joint can act as vertical joint shear reinforcement.</b></p>	6.8.1.6	3.10
<p>Horizontal transverse reinforcement:</p> <p>The diameter of the horizontal transverse reinforcement <math>\phi</math> should not be less than <b>8 mm</b> or one-quarter of the diameter of the largest column bar <math>\phi</math>, whichever is the greater.</p> <p>The spacing of transverse reinforcement <math>s_t</math> in the joint core should not exceed the least of the following:</p> <p>(a) ten times the diameter of the smallest column bar;</p> <p>(b) 200 mm;</p>	6.8.1.7	

<p>(c) one-quarter of the beam depth.</p> <p>At least 50% of the shear resistance provided by the reinforcement should be in the form of hoops. The remaining reinforcement may be in the form of crossties or U-bars with proper anchorages within the connecting beams.</p>		
<p>Where there is adequate confinement to prevent the end anchorage of the link from “kick off”, the 135° or 180° hook in the links or crossties may be replaced by a 90° hook.</p>	9.5.2.2	3.11

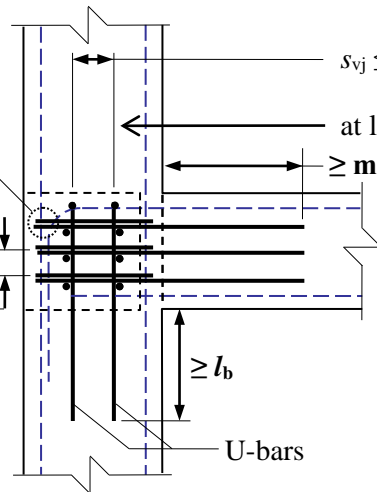
**Elevation**

Horizontal transverse reinforcement:

At least 50% of the shear resistance is provided by links.

$$\phi \geq \begin{cases} \phi/4 \\ 8 \text{ mm} \end{cases}$$

$$s_t \leq \begin{cases} 10\phi_{,min} \\ 200 \text{ mm} \\ h/4 \end{cases}$$

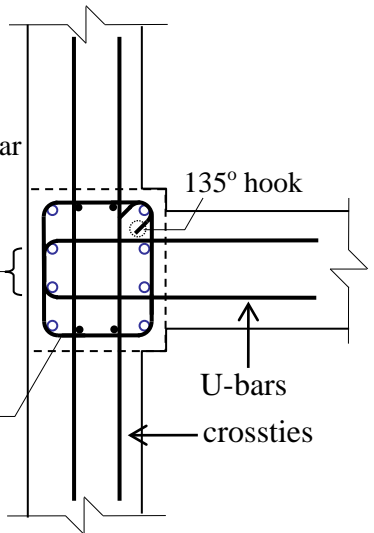


Vertical joint bars:

$$s_{vj} \leq \begin{cases} b_j/4 \\ 200 \text{ mm} \end{cases}$$

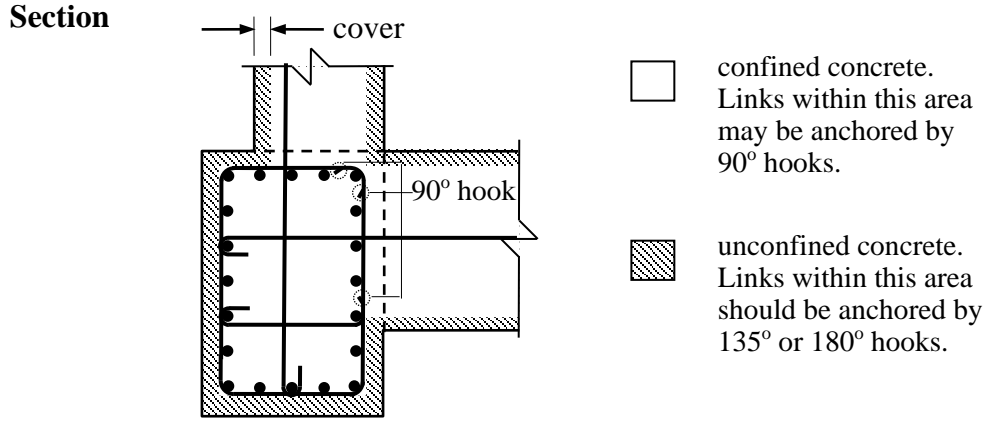
at least one vertical joint bar  $\geq \max(1.4l_b, 2h)$

Intermediate column bars act as vertical joints



- $b_j$  – lateral joint dimension
- $h$  – depth of beam
- $\phi$  – diameter of column bars
- $\phi$  – diameter of horizontal transverse reinforcement
- $l_b$  – ultimate anchorage bond length

**Figure 3.10** Reinforcement requirements for beam-column joints (same as Fig. 2.8)



**Figure 3.11** Confined and unconfined concrete regions of a beam-column joint (same as **Fig. 2.9**)

### 3.8 Drift ratio design formulas for rectangular walls

Drift ratio capacity models at 20% reduction in lateral strength were developed by Looi et al. (2016). The drift ratio capacity of rectangular RC walls at 0.8 of peak capacity can be obtained as follows:

*For flexural failure mode*

$$\theta_u = 1.4 \times 15 \left( \frac{v}{f_{cu,m}} SDR \right) 0.1^{ALR} 0.6^{\omega_v} 0.7^{\omega_h} 1.3^{C_1} \quad (3.1)$$

*For shear failure mode*

$$\theta_u = 1.0 \times 50 \left( \frac{v}{f_{cu,m}} SDR \right) 0.1^{ALR} 0.6^{\omega_v} 2.6^{\omega_h} 1.3^{C_1} \quad (3.2)$$

where

$N_{work}$  is the unfactored design axial load,

$M$  is the end moment,

$V$  is the end shear,

$v$  is the shear stress capacity of the wall section,

$A_g$  is the cross-section area of the wall,

$h_w$  is the depth of the wall,

$s_{t1}$ ,  $s_{t2}$  and  $s_{t3}$  are the dimensions of confined zone defined in **Figs. 3.12**.

$s_t$  is the vertical spacing of hoop steel

$f_{yl,m}$  is the mean yield strength of vertical reinforcement,

$f_{yh,m}$  is the mean yield strength of horizontal reinforcement,

$f_{yt,m}$  is the mean yield strength of hoop reinforcement

$f_{cu,m}$  is the mean concrete compressive strength of a cube,

$\rho_l$  is the area of vertical reinforcement ratio,

$\rho_h$  is the area of horizontal reinforcement ratio,

$\rho_{t,vol}$  = volume of hoop steel / ( $s_{t1} s_{t2} s_t$ )

$\omega_l = \rho_l f_{yl,m} / (0.8 f_{cu,m})$  is the mechanical ratio of vertical reinforcement,

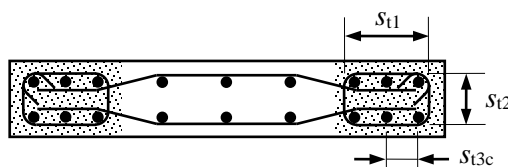
$\omega_h = \rho_h f_{yh,m} / (0.8 f_{cu,m})$  is the mechanical ratio of horizontal reinforcement,

$\omega_t = \frac{\rho_{t,vol} f_{yt,m}}{0.8 f_{cu,m}}$  is the mechanical ratio of hoop reinforcement

$ALR = N_{work} / (0.8 A_g f_{cu,m})$  is the axial load ratio (which should be limited to 0.5),

$SDR = M / (V h_w)$  is the shear span-to-depth ratio (which should be limited to 2.5), and

$$C_1 = \min \left[ 1, \sqrt{\left( \frac{s_{t1}}{s_t} \right) \left( \frac{s_{t1}}{s_{t3}} \right) \left( \frac{1}{\omega_t} \right)} \right].$$



**Figure 3.12** Definition of the dimensions used in the confined zone

### 3.9 References

ASCE (2010). Minimum Design Loads for Buildings and Other Structures. ASCE 7-10. American Society of Civil Engineers, Reston, VA.

BD (2013). *Code of Practice for Structural Use of Concrete*, Buildings Department, The Government of the HKSAR.

Fanella DA (2007). *Seismic detailing of concrete buildings*, 2<sup>nd</sup> Edition, Portland Cement Association, Illinois, USA.

Moehle JP, Ghodsi T, Hooper JD, Fields DC and Gedhada R (2012). *Seismic Design of Cast-in-Place Concrete Special Structural Walls and Coupling Beams – A Guide for Practicing Engineers, Report No. NIST GCR 11-917-11REV-1*, National Institute of Standards and Technology, U.S. Department of Commerce, USA.

Paulay T and Priestley MJN (1992). *Seismic Design of Reinforced Concrete and Masonry Buildings*, John Wiley & Sons, New York.



SRIA (2015). Guide to Seismic Design and Detailing of Reinforced Concrete Buildings in Australia, Steel Reinforcement Institute of Australia, Roseville, New South Wales, Australia.

Looi DTW, Su RKL, Cheng B and Zhou MJ (2016). Ultimate drift prediction models of rectangular squat RC shear walls, *Proceedings of the 24th Australasian Conference on the Mechanics of Structures and Materials*, Perth, 6-9 December 2016, 6 pages.

## 4 FRAME SYSTEMS

### 4.1 Scope

The detailing provisions described herein apply to regular and normally proportioned RC buildings not taller than 50 m using moment resisting frames as their primary earthquake force-resisting system. Under occasional earthquake, the anticipated BCR and IDR demands of regular RC frame buildings are not greater than 1.4% in either case. Under rare earthquake conditions, when a no-collapse limit state is explicitly considered, the maximum BCR and IDR demands are increased to 3.0%. If the design drift demands are higher than those anticipated, design formulas are provided to aid the seismic detailing design of RC beams and columns.

The detailing provisions presented in this Chapter aim to provide sufficient drift ratio capacity for RC members to cope with the aforementioned deformation demands.

### 4.2 Detailing considerations

In a moment resisting frame structural system, vertical and lateral loads are mainly supported by a spatial frame. As long as non-structural components are properly separated from the structure, their stiffening and strengthening effects during strong shaking can be ignored. In such case, reliable details should be adopted for the non-structural walls to prevent the potential out-of-plane failure. When the non-structural components cannot be separated from the structure, their structural effect, such as shortening the structural natural period and increasing the lateral stiffness of the frame should be considered in the seismic analysis. In such case, those non-structural components, e.g. infill partition walls, should be symmetrically arranged in plan and in elevation to minimise the vertical and torsional irregularities. In Hong Kong, the anticipated seismic force and displacement demands of regular RC frames – particularly those located on soil sites – can be very high, and the use of transfer structures which could further amplify the local seismic demands is not recommended. Short columns with an SDR below 2.0 should not be used as shear failure is prone to occur; such failure may lead to a dramatic reduction in gravity load carrying capacity and potentially lead to the collapse of buildings during strong earthquakes. Hence, parapet walls should be detached from frame structures so as to avoid turning slender columns into short columns.

When a building sways during ground shaking, the distribution of damage over the height depends on the distribution of the IDR. If the building has weak columns, drift tends to concentrate in one or a few storeys and may exceed the drift capacity of the columns, leading to general frame instability (see **Fig. 1.14(b)**). On the other hand, if columns provide a stiff and strong spine over the building height, drift will be more uniformly distributed, and localised damage will be reduced (see **Fig. 1.14(a)**). The capacity design approach, which aims to establish a favourable energy-dissipating mechanism and uniform distribution of IDR, should be adopted for the seismic design of RC frame buildings in order to reduce the

local deformation demands and avoid premature and soft-storey types of failures. The key features of the capacity design approach are described herein.

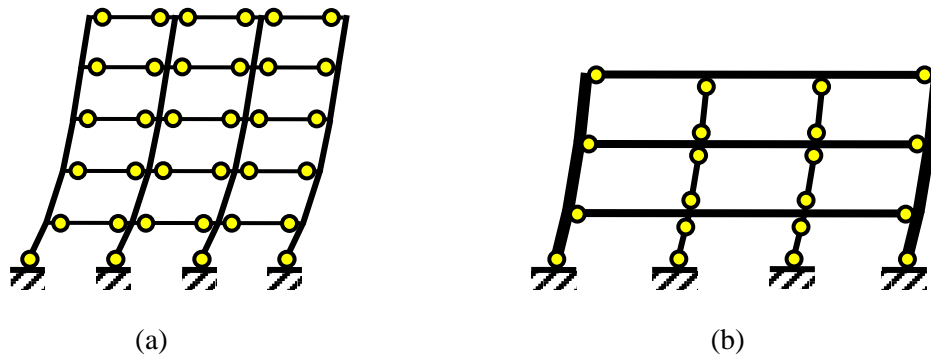
First, undesirable modes of failure associated with concrete failure in structural members are to be avoided, whereas ductile flexural failure in the form of stable reinforcement yielding is promoted. To achieve this, members are forced to fail in a ductile manner by ensuring the greater capacity of other possible failure modes. In the potential plastic hinge regions, the area of tension longitudinal reinforcement is limited to prevent the compressive failure of concrete. Further, sufficient well-anchored transverse reinforcement is provided in order to properly confine the concrete and restrain the reinforcement from possible buckling in the critical zone under reversed cyclic seismic loads. This design philosophy is known as “strong shear/weak moment”.

Second, a favourable hierarchy of member strength in a structure should be established. It is important to recognise that the columns in a given storey support the weight of the entire building above those columns, whereas the beams only support the gravity loads of the floor of which they form a part; therefore, failure of a column is of greater consequence than failure of a beam. Recognising this behaviour, worldwide seismic design practice normally specifies that columns should be stronger than beams, with a possible allowance for the expected flexural strength of beams, such that plastic hinges can form at the beam ends. It should be noted that when calculating the flexural strength of beams, the flange stiffening effects from the adjacent slabs should be considered. This strong column/weak beam principle is fundamental to achieving the safe behaviour of frames during strong quakes.

Lastly, the beam-column joint, which is a zone of intersection between beams and columns, is the most crucial zone in an RC moment resisting frame, and its behaviour has a significant influence on the response of the structure. The functional requirement of a joint is to enable the adjoining members to develop and sustain their ultimate capacity. The basic requirement of design is that the joint must be stronger than the adjoining beams or columns, with possible allowance for the expected strength of beam reinforcement. It is important to ensure during the initial design phase that the joint size is adequate; otherwise the column or beam size may subsequently need to be modified to satisfy the joint strength or anchorage requirements. This design principle is termed “strong joint/weak member”.

For more detailed information on the seismic design procedure of moment resisting frames using the capacity design approach, the interested reader can refer to Paulay and Priestley (1992).

- Potential plastic hinge



**Figure 4.1** Preferable energy dissipating mechanisms for frames with a (a) weak beam system and (b) strong beam system

Following the capacity design approach, some practical energy-dissipating mechanisms without excessive IDRs should first be selected during the seismic design process. Some of the more preferable mechanisms for frame systems are illustrated in **Fig. 4.1**. For the weak beam system, as shown in **Fig. 4.1(a)**, plastic hinges are formed in all the beams and at the base of all column members. Thus the complicated construction of the lapping of vertical reinforcement at the middle height of columns at upper levels can be completely avoided. However, when long-span beams are used, the flexural strength of the beams is typically much greater than that of the columns and, as such, it may be preferable to allow the development of plastic hinges at both ends of interior columns (see **Fig. 4.1(b)**). Soft-storey failure is avoided by providing strong columns along the building envelope.

In the design of simple regular frame buildings, an equivalent static method based on the force reduction factor approach could be sufficiently accurate for seismic design. However, for frames with significant irregularities or soil amplification effects, nonlinear static or dynamic analysis should be conducted to evaluate the seismic response under rare earthquake action. When the predicted maximum drift demand in the no-collapse limit state is higher than 3.0%, the drift ratio design formulas provided in **Section 4.6** may be used to aid the sectional and reinforcement detailing design of beams and columns.

### 4.3 Ductile columns

The ultimate drift ratio of RC columns primarily depends on the mode of failure, the ALR, the SDR and the transverse reinforcement percentage. In order to ensure that the ultimate drift ratio capacity can reach 3.0%, the SDR should not be less than 2.0 and sufficient transverse reinforcement should be provided to avoid brittle shear failure prior to ductile flexural failure. Furthermore, the transverse reinforcement percentage at the plastic hinge regions should not be less than 0.4% so as to ensure the required deformability of the column. In this Guide, the location of potential plastic hinges is denoted as a critical zone. The laps of longitudinal reinforcement should be located away from the critical zones. The detailing

provisions for the seismic design of ductile columns in which the larger dimension  $h_c$  is not greater than four times the smaller dimension  $b_c$  are summarised in **Table 4.1** and **Fig. 4.2**.

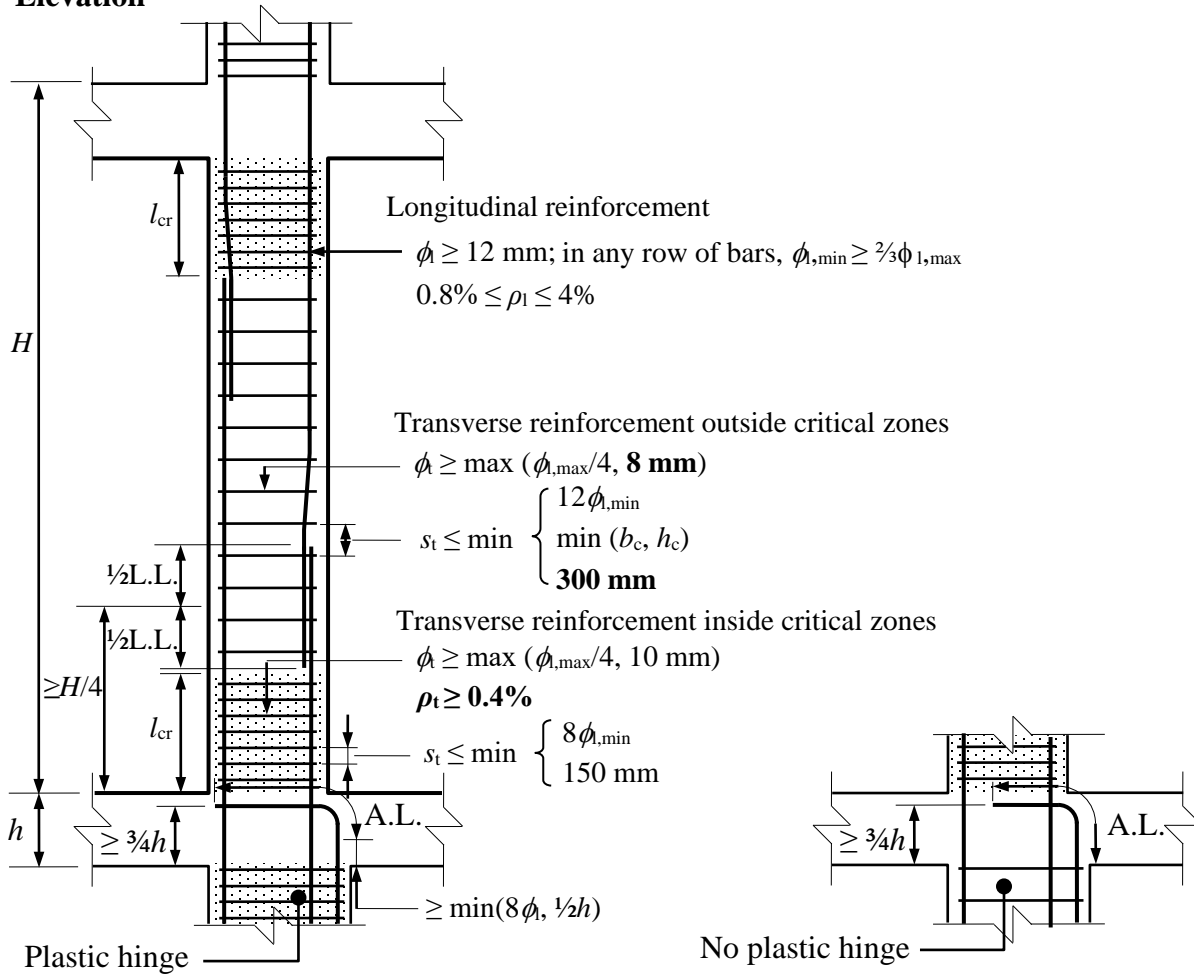
**Table 4.1.** Detailing requirements of ductile columns

Requirements	Clause No. (BD 2013)	Figure No.
<p><b><u>Shear span-to-depth ratio</u></b></p> <p><b>The shear span-to-depth ratio of column, which is defined as <math>M/(V \times h_c)</math>, should not be less than 2.0.</b></p>	N.A.	N.A.
<p>Longitudinal reinforcement:</p> <p>The minimum and maximum percentages of longitudinal reinforcement <math>\rho_l</math> based on the concrete cross-sectional area of a vertically-cast column are 0.8% and 4.0% respectively. At the laps, the reinforcement percentage may be increased to 5.2%. Furthermore, the sum of the reinforcement sizes in a particular layer of laps should not exceed 40% of the breadth of the section at that location.</p> <p>In any row of bars, the smallest bar diameter used should not be less than two thirds of the largest bar diameter used.</p> <p>The smallest bar diameter <math>\phi</math> should not be less than 12 mm.</p> <p>The minimum number of longitudinal bars in a column should be four in rectangular columns and six in circular columns. In columns with a polygonal cross-section, at least one bar should be placed at each corner.</p> <p>For longitudinal bars in potential plastic hinge regions, the restrained (cross-linked) bars should not be spaced further apart between centres than the larger of one-quarter of the adjacent lateral column dimension or 200 mm.</p> <p>Where column bars terminate in beam-column joints or joints between columns and foundation members, and where a plastic hinge in the column may be expected, the anchorage of the longitudinal column bars into the joint region should be assumed to commence at one-half of the depth of the beam or eight bar diameters <math>\phi</math>, whichever is less, from the face at which the column bar enters the beam or foundation member. When it is shown that a column plastic hinge adjacent to the beam face cannot occur, the development length should be considered to commence from the beam face.</p> <p>Column bars should be terminated in a joint area with a horizontal 90° standard hook (or equivalent anchorage device) as close to the far face of the beam as practicably possible, and not closer than three-quarters of the depth of the beam to the face of entry. Unless a column is designed to resist only axial forces, the direction of the horizontal leg of the bend must always be towards the far face of the column.</p>	9.5.1 and 9.9.2.1	4.2
<p>Critical zone:</p> <p>The critical zone <math>l_{cr}</math> in columns should extend from the point of maximum moment over a finite length, suggested as follows (including the zone influenced by the stub effect):</p> <p>For <math>0 &lt; N/(A_g f_{cu,k}) \leq 0.1</math>, the extent of the critical zone is taken as 1.0</p>	9.9.2.2	N.A.

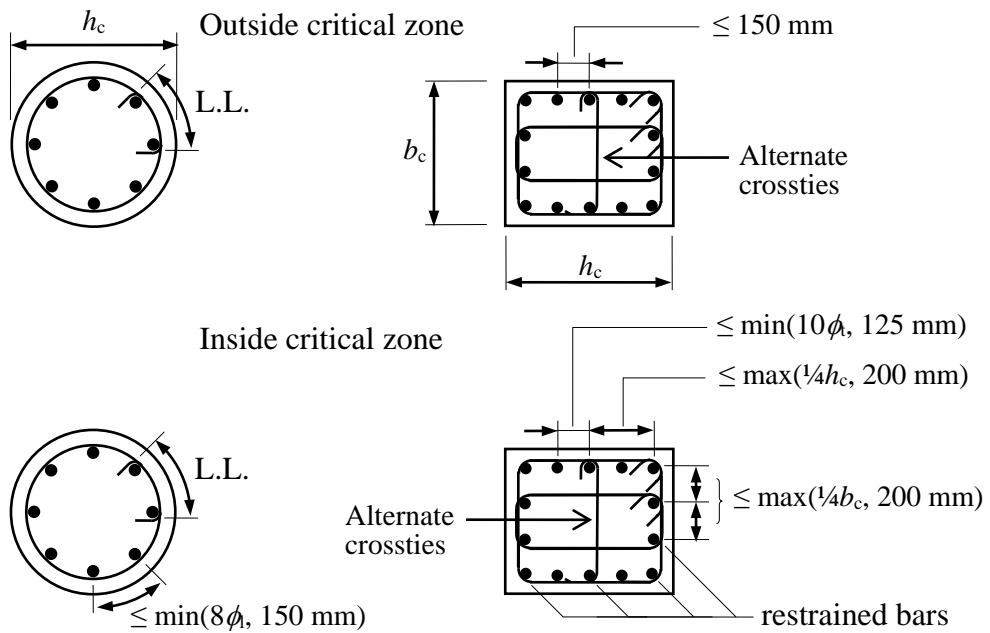
<p>times the greater dimension of the cross-section or where the moment exceeds 0.85 of the maximum moment or one-sixth of column clear height at the floor, whichever is larger; where <math>A_g</math> is the gross area of the section, <math>\text{mm}^2</math>.</p> <p>For <math>0.1 &lt; N/(A_g f_{cu,k}) \leq 0.3</math>, the extent of the critical zone is taken as 1.5 times the greater dimension of the cross-section or where the moment exceeds 0.75 of the maximum moment or one-sixth of column clear height at the floor, whichever is larger; and</p> <p>For <math>0.3 &lt; N/(A_g f_{cu,k}) \leq 0.6</math>, the extent of the critical zone is taken as 2.0 times the greater dimension of the cross-section or where the moment exceeds 0.65 of the maximum moment or one-sixth of column clear height at the floor, whichever is larger.</p>		
<p>Transverse reinforcement inside critical zones:</p> <p><b>The minimum percentage of transverse reinforcement <math>\rho_t</math> based on the concrete sectional area in the critical zone normal to the reinforcement bars is 0.4%.</b></p> <p>The diameter of the transverse reinforcement <math>\phi_t</math> should not be less than 10 mm or one-quarter of the diameter of the largest longitudinal bar <math>\phi_{l,max}</math>, whichever is the greater.</p> <p>For rectangular or polygonal columns, the centre-to-centre spacing of links or cross-ties <math>s_t</math> along a column should not exceed the smaller of eight times the diameter of the longitudinal bar <math>\phi</math> to be restrained or 150 mm. The arrangement of links or ties within the cross section should comply with either one of the following requirements:</p> <ul style="list-style-type: none"> <li>(i) each longitudinal bar or bundle of bars should be laterally supported by a link passing around the bar, or</li> <li>(ii) every corner bar and each alternate longitudinal bar (or bundle) in the outer layer of reinforcement should be supported by a link passing around the bar, and no bar within the compression zone should be further than the smaller of ten times the diameter of link <math>\phi_t</math> or 125 mm from a restrained bar.</li> </ul> <p>For circular columns, the centre-to-centre spacing of spirals or circular hoops along the column should not exceed the smaller of eight times the diameter <math>\phi</math> of the longitudinal bar to be restrained or 150 mm.</p> <p>Links and ties should be adequately anchored by means of 135° hooks.</p>	9.9.2.2	4.2
<p>Transverse reinforcement outside critical zones:</p> <p>The diameter of the transverse reinforcement <math>\phi_t</math> should not be less than <b>8 mm</b> or one-quarter of the diameter of the largest longitudinal bar <math>\phi</math>, whichever is the greater.</p> <p>The spacing of transverse reinforcement <math>s_t</math> along a column should not exceed the least of the following:</p> <ul style="list-style-type: none"> <li>(i) 12 times the diameter of the smallest longitudinal bar;</li> <li>(ii) the lesser dimension of the column;</li> <li>(iii) <b>300 mm.</b></li> </ul> <p>For rectangular or polygonal columns, all corner bars and alternate bars (or bundles) in an outer layer of reinforcement should be supported by links, with or without crossties, passing around the bars and should</p>	9.5.2.2 and 9.5.2.3	4.2

<p>have an included angle of not more than 135°. No bar within a compression zone should be further than 150 mm from a restrained bar.</p> <p>For circular columns, spiral transverse reinforcement should be anchored either by being welded to the previous turn, in accordance with clause 8.7, or by terminating the spiral with at least a 90° hook bent around a longitudinal bar, where the hook is no more than 25 mm from the previous turn.</p> <p>For rectangular or polygonal columns, links should be adequately anchored by means of hooks bent through an angle of not less than 135°. Crossties should be adequately anchored by means of hooks bent through an angle of not less than 135° at one end and 90° at the other end, and should be alternated end for end along the longitudinal bars.</p> <p>For circular columns, circular links should be anchored by either a mechanical connection or a welded lap, in accordance with clause 8.7, or by terminating each end of the link with at least a 90° hook bent around a longitudinal bar and overlapping the other end of the link. Spiral or circular links should not be anchored by straight lapping.</p>		
--	--	--

**Elevation**



**Section**



L.L. – Lap length; A.L. – Anchorage length

**Figure 4.2** Reinforcement requirements for ductile columns



## 4.4 Ductile frame beams

The detailing provisions described below are applicable to ductile frame beams with normal proportions exhibiting expected ultimate chord rotations of not less than 3.0%. Deep beams are not considered. For the design of deep beams, reference should be made to specialist literature. The location of the potential plastic hinges is denoted as a critical zone. Laps of reinforcement should be located away from the critical zones. The detailing requirements of ductile beams are summarised in **Table 4.2** and **Figs. 4.3** and **4.4**.

**Table 4.2.** Detailing requirements of ductile frame beams (same as **Table 3.4**)

Requirements	Clause No. (BD 2013)	Figure No.
<p>Critical zones:</p> <p>The critical zone is equal to two times the beam depth extending from the column face.</p>	9.9.1.1	4.3
<p>Longitudinal reinforcement inside the critical zone:</p> <p>The minimum percentages of longitudinal reinforcement appropriate for various conditions of loading are given in Table 9.1 (clause 9.2.1.1) and should not be less than 0.3% (clause 9.9.1.2) (BD 2013).</p> <p>The maximum percentages of tension reinforcement should not exceed <b>4%</b> of the gross cross-sectional area of the concrete (clause 9.9.1.2).</p> <p><b>The minimum percentages of compression reinforcement should not be less than 0.35 of tension reinforcement at the same section.</b></p> <p>The maximum clear distance between adjacent bars in tension should not exceed <math>70,000 \beta_b / f_{yl} \leq 300</math> mm, where <math>\beta_b</math> and <math>f_{yl}</math> are the redistribution ratio and estimated service stress in the longitudinal reinforcement respectively, as defined in clause 9.2.1.4.</p> <p>When longitudinal beam bars are anchored in cores of exterior columns or beam stubs, the tension anchorage should be deemed to commence at one-half of the relevant column depth or eight times the bar diameter <math>\phi</math>, whichever is less, from the face at which the beam bar enters the column. Where it can be shown that the critical section of the plastic hinge is at a distance of at least the beam depth or 500 mm, whichever is less, from the column face, the anchorage length may be considered to commence at the column face (clause 9.9.1.2).</p> <p>No bar should be terminated without a vertical 90° standard hook or equivalent anchorage device as near as practicably possible to the far side of the column core, or the end of the beam stub where appropriate, and not closer than three-quarters of the relevant column depth to the face of entry (clause 9.9.1.2).</p> <p>Top beam bars should only be bent down and bottom bars should only be bent up (clause 9.9.1.2).</p>	9.2.1.1, 9.2.1.4 and 9.9.1.2	4.3
<p>Longitudinal reinforcement outside the critical zone:</p> <p>The minimum percentages of longitudinal reinforcement appropriate for various conditions of loading are given in Table 9.1 (clause 9.2.1.1) (BD 2013).</p>	9.2.1.1, 9.2.1.3, 9.2.1.4 and 9.9.1.2	4.3

<p>The maximum percentages of longitudinal reinforcement should not exceed 4% of the gross cross-sectional area of the concrete (clause 9.2.1.3).</p> <p>At the laps, the sum of the diameter of all reinforcement bars in a particular layer should not exceed 40% of the breadth of the section at that location (clause 9.2.1.3).</p> <p>The maximum clear distance between adjacent bars in tension should not exceed <math>70,000 \beta_b / f_{yl} \leq 300</math> mm, where <math>\beta_b</math> and <math>f_{yl}</math> are the redistribution ratio and estimated service stress in the longitudinal reinforcement respectively, as defined in clause 9.2.1.4.</p>		
<p>Transverse reinforcement inside the critical zone:</p> <p>The maximum spacing of the links in the direction of the span should not exceed <math>0.75d</math> (clause 9.2.2) and the larger of 150 mm or eight times the smallest diameter of longitudinal bars <math>\phi_{\min}</math> (clause 9.9.1.3).</p> <p>Links or ties should be arranged so that every corner and alternate compression longitudinal bar is restrained by a leg (clause 9.9.1.3).</p> <p>At right-angles to the span, the horizontal spacing of legs should not exceed the smaller of 20 times the diameter of link <math>\phi</math> or 250 mm (clause 9.9.1.3).</p> <p>Furthermore, no longitudinal tension bar should be more than 150 mm from a vertical leg (clause 9.2.2).</p> <p>Links should be adequately anchored by means of <math>135^\circ</math>, <b>150°</b> or <math>180^\circ</math> hooks. Where there is adequate confinement to prevent the end anchorage of the link from “kick off”, the <math>135^\circ</math> hook may be replaced by other standard anchorages (<b>Fig. 4.4</b>), as mentioned in clause 9.9.1.3.</p>	9.2.2 and 9.9.1.3	4.3 and 4.4
<p>Transverse reinforcement outside the critical zone:</p> <p>The maximum spacing of the links in the direction of the span should not exceed <math>0.75d</math> (clause 9.2.2), the smaller of the least lateral dimension of the cross section of the beam or 12 times the smallest bar diameter of the longitudinal bars <math>\phi_{\min}</math> (clause 9.9.1.3).</p> <p>Links or ties should be arranged so that every corner and alternate compression longitudinal bar is restrained by a leg (clause 9.9.1.3).</p> <p>At right-angles to the span, no longitudinal tension bar should be more than 150 mm from a vertical leg (clause 9.2.2).</p> <p>Links should be adequately anchored by means of <math>135^\circ</math>, <b>150°</b> or <math>180^\circ</math> hooks. Where there is adequate confinement to prevent the end anchorage of the link from “kick off”, the <math>135^\circ</math> hook may be replaced by other standard anchorages (<b>Fig. 4.4</b>), as mentioned in clause 9.9.1.3.</p>	9.2.2 and 9.9.1.3	

**Inside the critical zone**

Longitudinal bars:

Min. steel according to Table 9.1 and  $\geq 0.3\%$ ,

Max. tension steel  $\leq 4\%$ ,

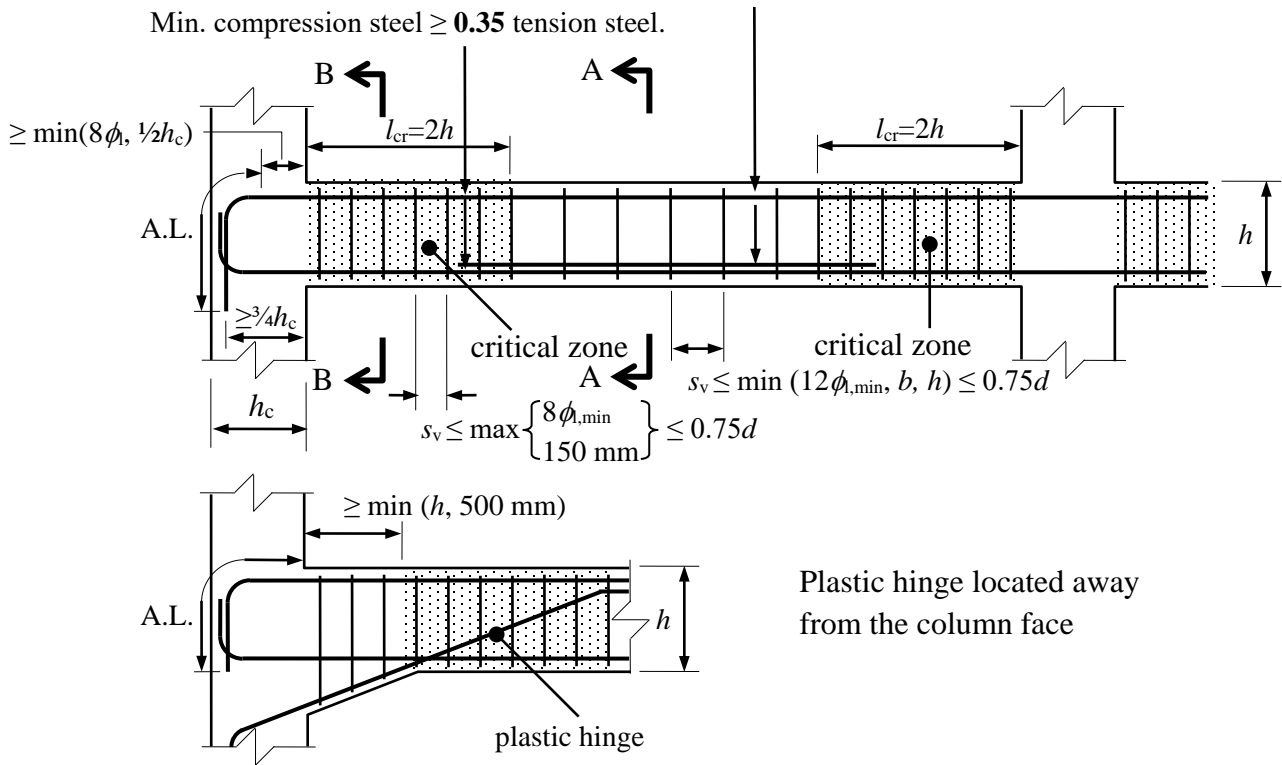
Min. compression steel  $\geq 0.35$  tension steel.

**Outside the critical zone**

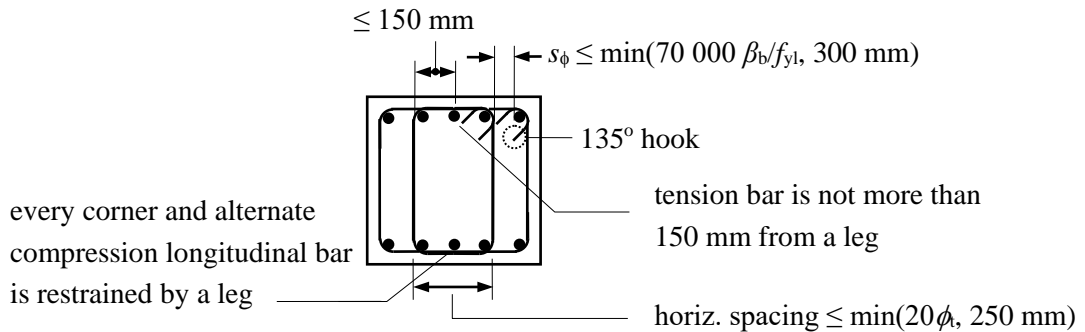
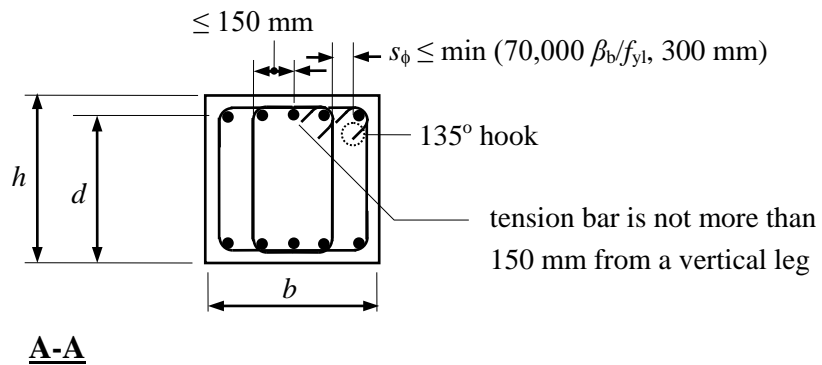
Longitudinal bars:

Min. steel according to Table 9.1 and  $\geq 0.3\%$ ,

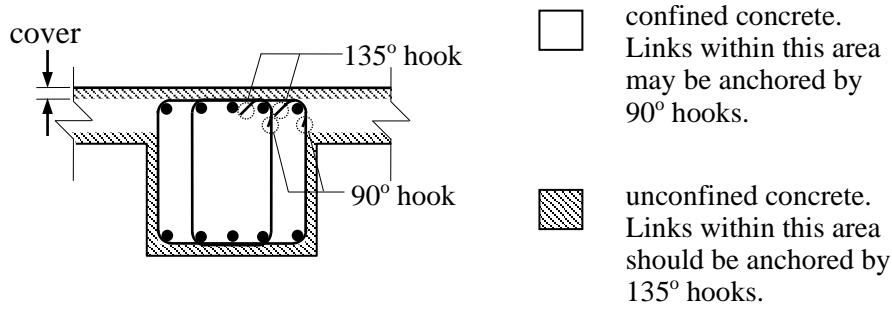
Max. tension steel  $\leq 4\%$ .



A.L. – Anchorage Length



**Figure 4.3** Reinforcement requirements for ductile frame beams (same as **Fig. 3.8**)



**Figure 4.4** Reinforcement requirements for beams confined with slabs (same as **Fig. 3.9**)

## 4.5 Beam-column joints

The overall integrity of RC frames depends on the behaviour of beam-column joints. Degradation of joints during seismic action can result in large lateral deformations, which can cause excessive damage or even collapse of the frame. In the 1980 El Asnam, the 1985 Mexico, the 1986 San Salvador, and the 1989 Loma Prieta earthquakes, many beam-column joint failures were observed; this was particularly the case for exterior joints associated with shear and anchorage failures (Paulay and Priestley, 1992).

The seismic design of beam-column joints should satisfy the following criteria, in accordance with clause 6.8.1.1:

- (a) at serviceability limit state, a joint should perform at least as well as the members that it joins; and
- (b) at ultimate limit state, a joint should have a design strength sufficient to resist the most adverse load combinations sustained by the adjoining members.

The detailing provisions summarised in **Table 4.3** and **Figs. 4.5** and **4.6** are applicable to beam-column joints.

**Table 4.3.** Detailing requirements of beam-column joints (same as **Table 2.6**)

Requirements	Clause No. (BD 2013)	Figure No.
<p>Vertical joint shear reinforcement:</p> <p>Centre-to-centre spacing <math>s_{vj}</math> of the vertical joint shear reinforcement in either direction should not exceed 200 mm or one-quarter of the lateral dimension of the joint <math>b_j</math> in the orthogonal direction, whichever is the larger.</p> <p>Each vertical face of the joint should be provided with at least one vertical joint shear bar.</p> <p><b>Intermediate column bars located at each side within the beam-column joint can act as vertical joint shear reinforcement.</b></p>	6.8.1.6	4.5
<p>Horizontal transverse reinforcement:</p> <p>The diameter of the horizontal transverse reinforcement <math>\phi</math> should not be less than <b>8 mm</b> or one-quarter of the diameter of the largest column bar <math>\phi</math>, whichever is the greater.</p> <p>The spacing of transverse reinforcement <math>s_t</math> in the joint core should not exceed the least of the following:</p> <p>(a) ten times the diameter of the smallest column bar;</p> <p>(b) 200 mm;</p> <p>(c) <b>one-quarter of the beam depth.</b></p> <p><b>At least 50% of the shear resistance provided by the reinforcement should be in the form of hoops. The remaining reinforcement may be in the form of cross-ties or U-bars with proper anchorages within the connecting beams.</b></p>	6.8.1.7	
<p>Where there is adequate confinement to prevent the end anchorage of the link from “kick off”, the <b>135° or 180° hook</b> in the links or cross-ties may be replaced by a 90° hook.</p>	9.5.2.2	4.6

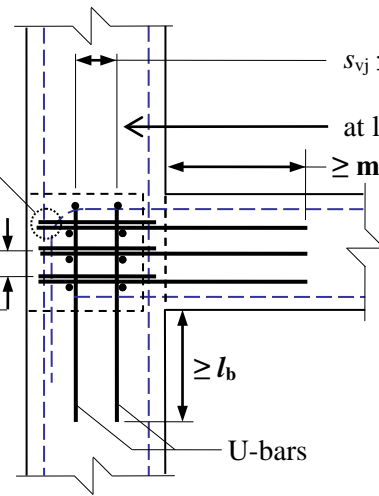
### Elevation

Horizontal transverse reinforcement:

At least 50% of the shear resistance is provided by links.

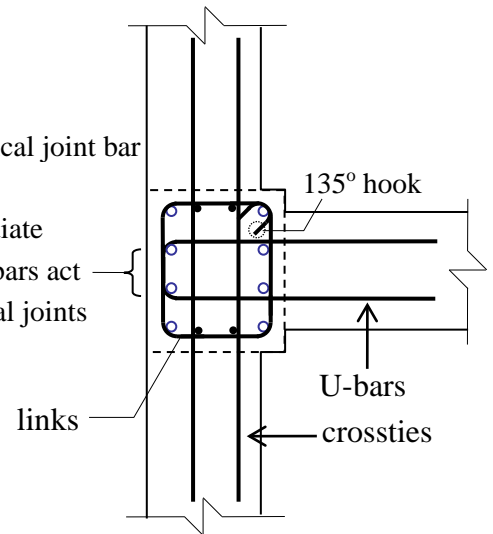
$$\phi \geq \begin{cases} \phi/4 \\ 8 \text{ mm} \end{cases}$$

$$s_t \leq \begin{cases} 10\phi_{l,\min} \\ 200 \text{ mm} \\ h/4 \end{cases}$$



### Section

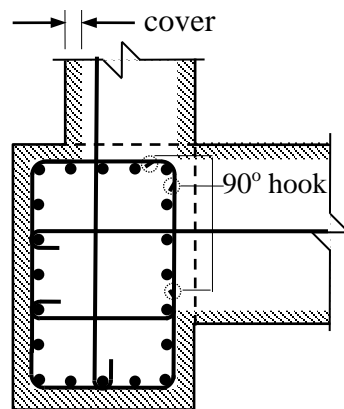
Vertical joint bars:



- $b_j$  – lateral joint dimension
- $h$  – depth of beam
- $\phi$  – diameter of column bars
- $\phi$  – diameter of horizontal transverse reinforcement
- $l_b$  – ultimate anchorage bond length

**Figure 4.5** Reinforcement requirements for beam-column joints (same as **Fig. 2.8**)

### Section



- confined concrete. Links within this area may be anchored by 90° hooks.
- unconfined concrete. Links within this area should be anchored by 135° or 180° hooks.

**Figure 4.6** Confined and unconfined concrete regions of a beam-column joint (same as **Fig. 2.9**)

Wu (2015) and Kong (2015) conducted nonlinear time history analyses of regular RC frames under Hong Kong rare earthquake conditions in order to evaluate the seismic performance of joints with various flexural strength ratios between columns and beams. Their results demonstrated that the shear force demands of interior joints are slightly higher than those of exterior joints for frames designed in accordance with the strong column/weak beam principle. The empirical formula proposed by Tran et al. (2014) for predicting the joint shear strength of beam-column joints demonstrated that the shear strength capacities of exterior empty joints are significantly smaller than those of interior empty joints. Therefore,

exterior beam-column joints are more vulnerable than interior beam-column joints under seismic action. When the flexural strengths of the beam and the column adjoining the joint are comparable, the shear force demands in the beam-column joints will be more critical. Empty exterior joints without transverse reinforcement are no longer sufficient for resisting rare earthquake actions. However, in frames designed in accordance with the strong column/weak beam principle, the joint shear demand to strength ratios are generally small and the joints behave elastically. Empty joints could meet the strength requirement.

The local design code (BD, 2013) assumes that the joint shear is resisted by a strut mechanism comprising a diagonal concrete strut and a truss mechanism comprising horizontal and vertical joint shear reinforcement and numerous diagonal concrete struts. The diagonal concrete strut mechanism is further assumed to contribute at least 50% to the total shear strength capacity, further increasing as the axial compressive load acting on the joint increases. The influence of confinement stress on the increase in strength of concrete strut and the reinforcement–concrete bond condition (especially in relation to the bond between the beam bars and the concrete at the joint core) is conservatively ignored. As the codified design model can only be used to determine the joint reinforcement but not the strength capacity of beam-column joints, it is not possible to validate the joint design model through the available experimental results. As such, a more comprehensive joint shear strength design model, which can be verified by test results, may need to be developed.

#### 4.6 Drift ratio design formulas for columns and beams

Probabilistic drift capacity models at 20% reduction in lateral strength were developed by Zhu (2005) and Zhu et al. (2007) based on a Bayesian method (Gardoni et al., 2002). When shear failure mode has been suppressed by the strong shear/weak moment design principle, and where the SDR is not less than 2.0, the median prediction of the drift ratio capacity of rectangular RC columns at 0.8 of peak capacity can be obtained as follows (Zhu et al., 2007):

$$\theta_u = 0.049 + 0.716\rho_l + 0.150 \frac{\rho_t f_{yt,m}}{f_{cu,m}} - 0.042 \frac{s_t}{h_c} - 0.07 ALR \quad (4.1)$$

where

- $\rho_l$  is the area of longitudinal reinforcement ratio,
- $\rho_t$  is the area of transverse reinforcement ratio,
- $f_{yt,m}$  is the mean yield strength of transverse reinforcement,
- $f_{cu,m}$  is the mean concrete compressive strength of a cube,
- $s_t$  is the vertical spacing of transverse reinforcement,
- $h_c$  is the depth of a column,

$$ALR = \frac{N_{work}}{0.8A_g f_{cu,m}} \text{ is the axial load ratio,}$$

$N_{work}$  is the unfactored design axial load, and  
 $A_g$  is the cross-section area of a column.

For rectangular RC columns that would fail in shear, the median prediction of the drift ratio capacity of columns at 0.8 of peak capacity can be expressed as follows (Zhu et al., 2007):

$$\theta_u = 2.02\rho_t - 0.025\frac{s_t}{h_c} + 0.013\frac{M}{Vh_c} - 0.031ALR \quad (4.2)$$

where

$M$  is the end moment, and

$V$  is the end shear.

The empirical formula for estimating the ultimate chord rotations,  $\theta_u$ , of RC beams without diagonal reinforcement in a primary seismic resisting system with proper detailing for earthquake resistance associated with flexure-controlled failure under cyclic or monotonic loading is presented as (BSI, 2005):

$$\theta_u = 0.0107(0.3^{ALR}) \left[ \frac{\max(0.01; \omega_2)}{\max(0.01, \omega_1)} f'_{c,m} \right]^{0.225} [\min(9; SDR)]^{0.35} 25^{[(\alpha\rho_v f_{yv,m})/f'_{c,m}]} \quad (4.3)$$

in which

$h$  is the beam depth;

SDR is the shear span-to-depth ratio at the end section;

ALR is the axial load ratio;

$\omega_1 = (\rho_{l1} f_{yl1,m} + \rho_{lw} f_{ylw,m}) / f'_{c,m}$  is the total reinforcement ratio of tension (steel ratio of  $\rho_{l1}$  and mean yield strength of  $f_{yl1,m}$ ) and web longitudinal bars (steel ratio of  $\rho_{lw}$  and mean yield strength of  $f_{ylw,m}$ );

$\omega_2 = \rho_{l2} f_{yl2,m} / f'_{c,m}$  is the reinforcement ratio of compression longitudinal bars (steel ratio of  $\rho_{l2}$  and mean yield strength of  $f_{yl2,m}$ );

$f'_{c,m}$  and  $f_{yv,m}$  are the mean concrete cylinder compression strength (MPa) and the mean shear reinforcement yield strength (MPa) respectively.  $f'_{c,m}$  may be assumed to be  $0.8f_{cu,m}$ ;

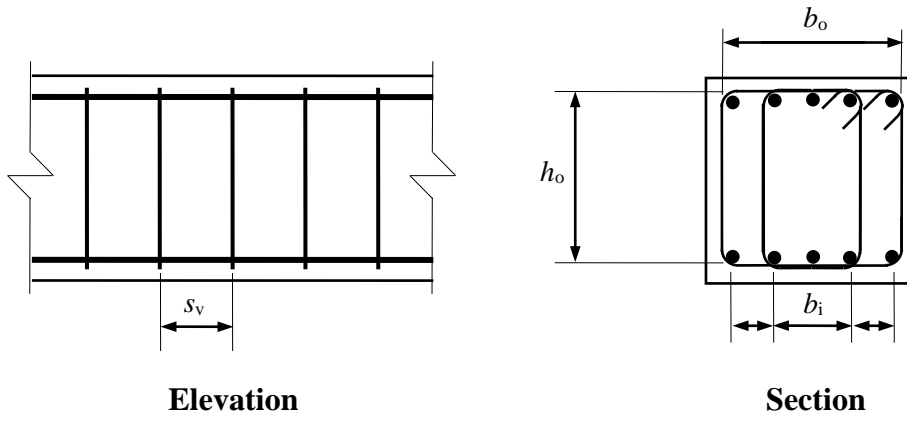
$\rho_v$  is the area ratio of the transverse reinforcement;

$\alpha$  is the confinement effectiveness factor according to Sheikh and Uzumeri (1982):

$$\alpha = \left(1 - \frac{s_v}{2b_0}\right) \left(1 - \frac{s_v}{2h_0}\right) \left(1 - \frac{\sum b_i^2 / 6}{b_0 h_0}\right) \quad (4.4)$$

in which  $s_v$  is the spacing of links along the beam;  $b_0$  and  $h_0$  are the dimensions of the confined core to the centre-line of the link; and  $b_i$  is the centre-line spacing along the section's perimeter of the longitudinal bars (indexed by  $i$ ) which are engaged by a link corner or a cross-tie (**Fig. 4.7**).





**Figure 4.7** Definitions of dimension parameters for computing confinement effectiveness factor

## 4.7 References

- BD (2013). *Code of Practice for Structural Use of Concrete, Buildings Department*, The Government of the HKSAR.
- BSI (2005). *Eurocode 8: Design of Structures for Earthquake Resistance, Part 3: Assessment and Retrofitting of Buildings*, British Standards Institute, UK.
- Gardoni P, Der Kiureghian A and Mosalam KM (2002). Probabilistic capacity models and fragility estimates for reinforced concrete columns based on experimental observations. *Journal of Engineering Mechanics - ASCE*, **128**, pp. 1024-1038.
- Kong LC (2015). *Strength Capacity of Reinforced Concrete Beam-column Joints*, Final Year Project Report, Department of Civil Engineering, The University of Hong Kong.
- Paulay T and Priestley MJN (1992). *Seismic Design of Reinforced Concrete and Masonry Buildings*, John Wiley & Sons, New York.
- Sheikh SA and Uzumeri SM (1982). Analytical model for concrete confinement in tied columns, *Journal of Structural Division*, **108**, pp. 2703-2722.
- Wu WJ (2015). *Strength Capacity of Reinforced Concrete Beam-column Joints*, MSc Thesis, Department of Civil Engineering, The University of Hong Kong.
- Zhu L (2005). *Probabilistic drift capacity models for reinforced concrete columns*, MASc thesis, Department of Civil Engineering, University of British Columbia, Vancouver, Canada.
- Zhu L, Elwood KJ and Haukaas T (2007). Classification and seismic safety evaluation of existing reinforced concrete columns, *Journal of Structural Engineering*, ASCE, **133**, pp. 1316-1330.