



CONSTRUCTION
INDUSTRY COUNCIL
建造業議會

General Welder Trade Test Mock Practical Test Paper

此文件關於普通焊接工工藝測試考題。如有需要索取此文件的中文版本，請致電 2100 9000 與香港建造業工藝測試中心聯絡。

Disclaimer

No part of this material may be reproduced or transmitted in any form or any means without the written permission of the CIC. Whilst reasonable efforts have been made to ensure the accuracy of the information contained in this material, the CIC nevertheless would encourage readers to seek appropriate independent advice from their professional advisers where possible and readers should not treat or rely on this material as a substitute for such professional advice for taking any relevant actions.

Enquiries

Enquiries on this Material may be made to the Hong Kong Construction Industry Trade Testing Centre at:

95, Yue Kwong Road
Aberdeen
Hong Kong

Tel: (852) 2100 9000
Fax: (852) 2100 9090
Email: enquiry@cic.hk
Website: www.cic.hk

© 2020 Construction Industry Council.

Trade Test Paper

Post : General Welder

Grade : Skilled Worker

Test Contents : Complete the following tasks according to the attached drawings at designated location

1. According to “Drawing 1 & 2”, use appropriate (70%) electrodes and current to weld work pieces in vertical, flat and overhead positions. You are not allowed to turn the work pieces if the work pieces have been connected by tack weld.
(You are required to fit up the steel members by tack weld according to drawings.)

2. Use oxy-acetylene device to cut a mild steel plate. (30%)
You are required to set up the cutting tools and adjust the pressure. After cutting, disconnect the cutting device. The mild steel plate shall be welded on the work pieces of task 1 according to “Drawing No. 1 & 2”.
(The examiner will stop the candidate to use the oxy-acetylene device if unsafe act is observed).

Duration : 6 hours (excluding lunch time)

Notes : (1) Candidate shall read the attached test requirements carefully;
(2) Candidate will be marked as fail if he does not carry out safety precautions during the test;
(3) The test paper consists of 5 pages. Total score is 100. Pass mark is 60

DRAWING NO.1

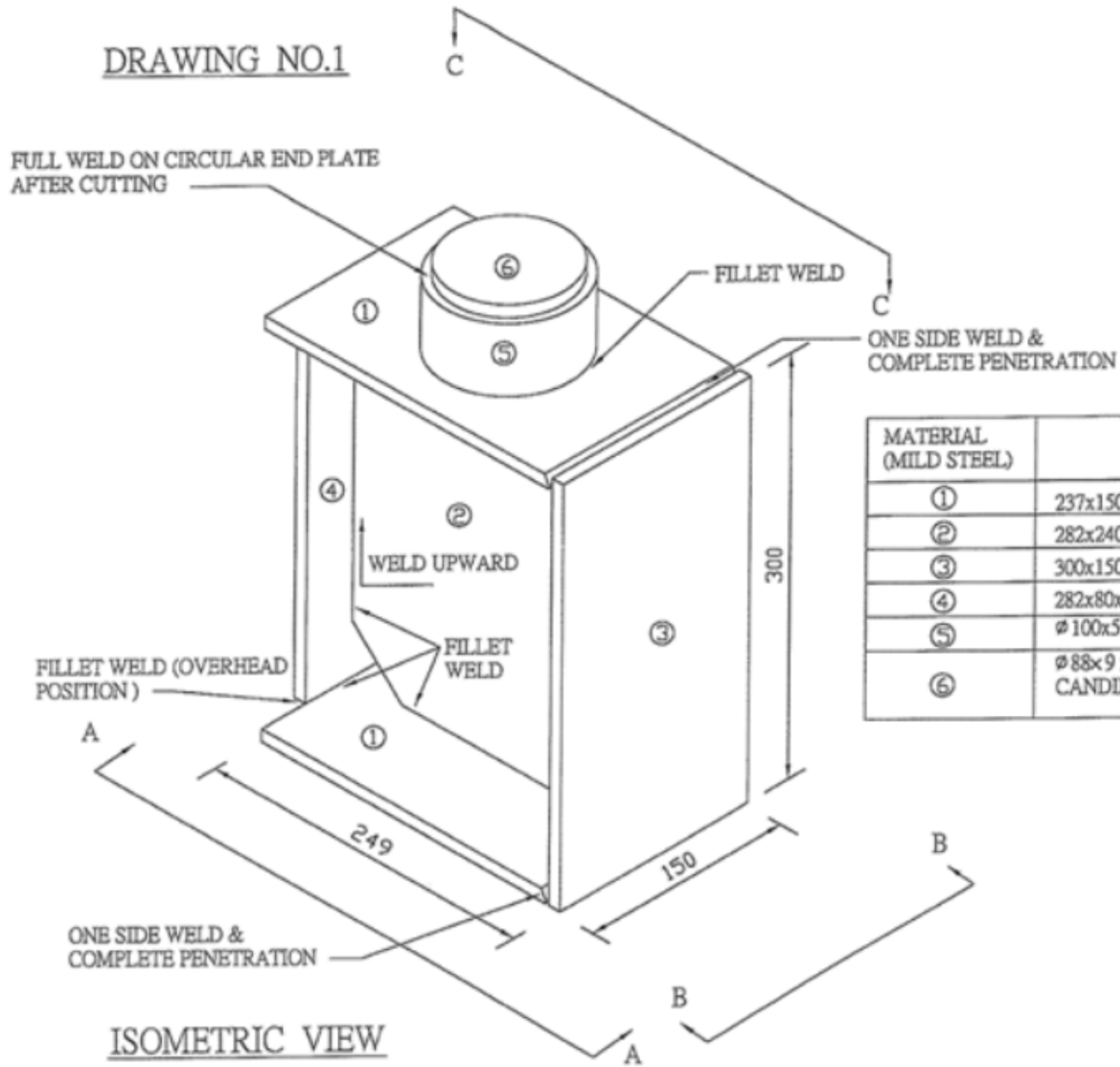

| MATERIAL (MILD STEEL) | SIZE |
|-----------------------|---|
| ① | 237x150x9 x2pcs. FLAT BAR |
| ② | 282x240x6 x1pc. PLATE |
| ③ | 300x150x9 x1pc. FLAT BAR |
| ④ | 282x80x9 x1pc. FLAT BAR CUT OFF BY CANDIDATE |
| ⑤ | ∅100x50 x1pc. TUBE |
| ⑥ | ∅88x9 x1pc. CIRCULAR PLATE CUT OFF BY CANDIDATE |

ALL DIMENSION ARE IN MILLIMETER
DRAWING IS NOT TO SCALE

DRAWING NO. 2

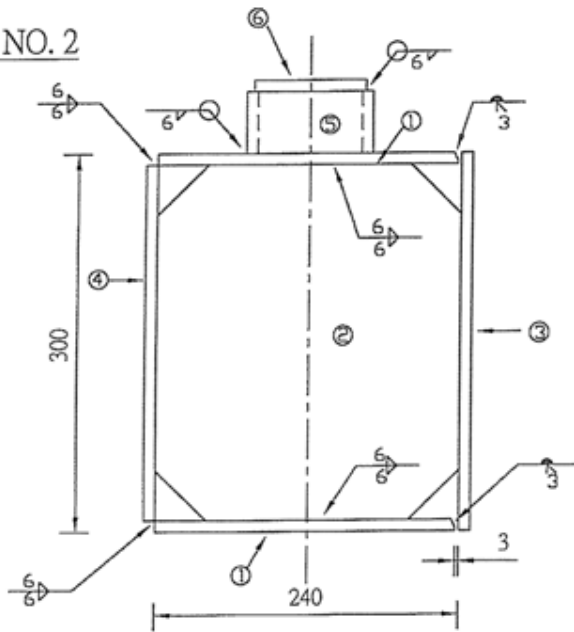

VIEW A-A

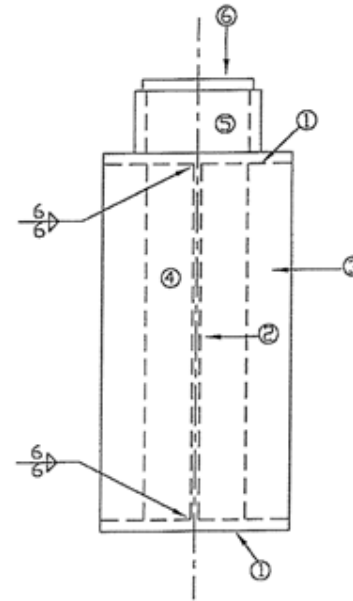

VIEW B-B

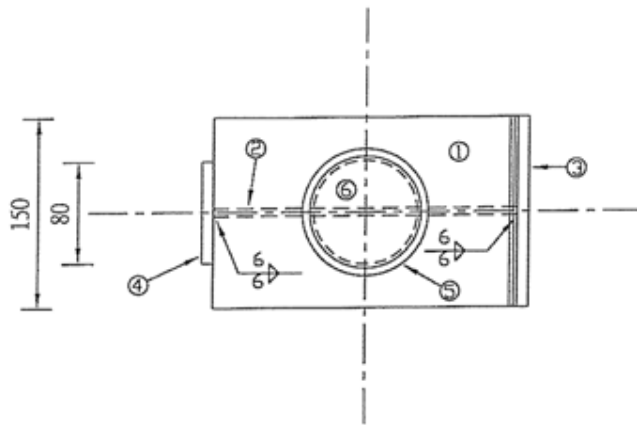

VIEW C-C

Specifications & Requirements

1. Electrode: E7016, $\phi 3.2$.
2. Weld in indicated position after the work pieces being connected by tack weld.
3. Butt joint must be on one side weld with complete penetration.
4. Fillet weld size must be in compliance with the drawing.
5. Slag inclusion, porosity, undercut, crack and etc. are not acceptable.
6. Alignment tolerance of workpieces $>2.5\text{mm}$ shall not be acceptable.
7. Cosmetic welding is not allowed. Slag & spatter must be removed after welding.

ALL DIMENSIONS ARE IN MILLIMETRE
DRAWING IS NOT TO SCALE

DRAWING NO.3

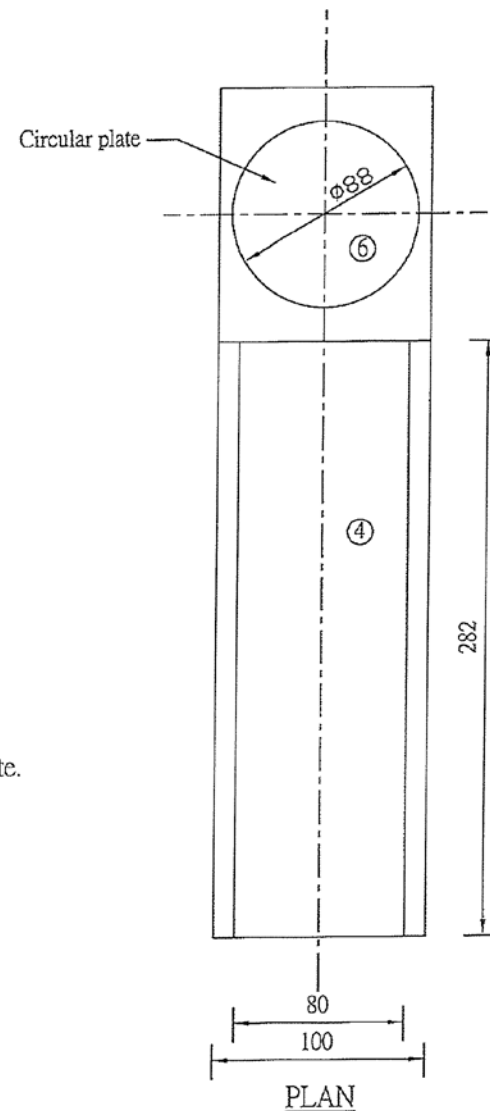
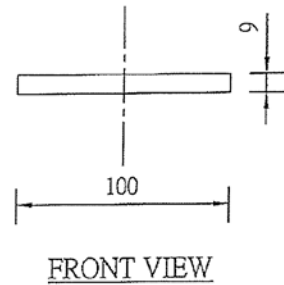

Specification & Requirements

1. Cut the straight lines and the circular plate which have been drawn on the mild steel plate.
2. Candidate should cut the workpiece with cutting torch on floor.
3. Width of kerf shall not exceed 3mm.
4. Tolerance of the kerf's straightness shall not exceed 3mm (length of workpiece).
5. Roughness of kerf shall not exceed 3mm.
6. Perpendicularity of kerf shall not exceed 1mm.
7. The slag attached on the bottom of kerf shall be removable.
8. After cutting the workpiece ④ & ⑥ which must be installed and welded complying with drawing No.1 & 2.

ALL DIMENSIONS ARE IN MILLIMETER
DRAWING IS NOT TO SCALE

Notes to Candidates :

1. Candidates should read the test papers carefully and ask the invigilator for any queries.
2. Candidates should study the drawings and specifications attached to test papers, if any, before the test begins.
3. Candidates should carry out the test according to test papers, working drawings and specifications provided.
4. Candidates shall bring their own safety shoes, other safety equipment will be provided by trade testing centre. Candidates must take all necessary safety precautions to ensure work safety.
5. All tools and materials required by the test will be provided by trade testing centre, candidates should check and ensure their adequacy and quality. Candidates shall use the tools and materials properly based on trade practice. All the tools must be returned to trade testing centre after the test. The candidates may ask the invigilator for any problems.
6. Candidates are required to handle and move the tools and materials for use in the test, and to carry out associated works.
7. Invigilator will take record photos periodically during the test.
8. Candidates are not allowed to take any photo or video with cameras or mobile phones.
9. Candidates are not allowed to use their mobile phones during the trade tests, except for emergency situation.
10. The marking scheme is based on the following criteria :
 - a) Understanding of drawing and specification
 - b) Preparation works before commencement of test

- c) Working procedures
- d) Accuracy and quality of works
- e) Progress of works
- f) Proper handling and use of materials
- g) Proper use of tools and equipment
- h) Safety precautions
- i) Considerate of other trades
- j) Housekeeping after completion of test

11. All candidates must stop when time is up.
12. Candidates are required to return the test paper to invigilator after the test.
13. Offering bribe to invigilator is an offence in law and trade testing centre will report to the ICAC for any such case.

In the event that the candidate fails to take any necessary safety precautions and / or works in any dangerous situations, he / she will be assessed failed