



CONSTRUCTION  
INDUSTRY COUNCIL  
建造業議會

# Metal Worker Trade Test Mock Written Test Paper

此文件關於金屬工工藝測試考題。如有需要索取此文件的中文版本，請致電 2100 9000 與香港建造業工藝測試中心聯絡。

## **Disclaimer**

*No part of this material may be reproduced or transmitted in any form or any means without the written permission of the CIC. Whilst reasonable efforts have been made to ensure the accuracy of the information contained in this material, the CIC nevertheless would encourage readers to seek appropriate independent advice from their professional advisers where possible and readers should not treat or rely on this material as a substitute for such professional advice for taking any relevant actions.*

## **Enquiries**

Enquiries on this Material may be made to the Hong Kong Construction Industry Trade Testing Centre at:

95, Yue Kwong Road  
Aberdeen  
Hong Kong

Tel: (852) 2100 9000  
Fax: (852) 2100 9090  
Email: [enquiry@cic.hk](mailto:enquiry@cic.hk)  
Website: [www.cic.hk](http://www.cic.hk)

© 2020 Construction Industry Council.

1. What is the main purpose of using H-beam in building construction ?
  - (a) easy to handle
  - (b) easy to erect
  - (c) easy to purchase
  - (d) acquire higher strength with less quantity of material
  
2. What is the colour of pure copper ?
  - (a) yellow
  - (b) sorrel
  - (c) blue
  - (d) green
  
3. The welding position of structure steel should :
  - (a) be in flat position whenever possible
  - (b) be in any position
  - (c) not be in overhead position without approval
  - (d) both (a) & (c)
  
4. After shear cutting a mild steel plate, the deformation (if any) should be :
  - (a) ignored
  - (b) minimized after welding
  - (c) made good
  - (d) both (a) & (b)

5. Which of the following personal protection equipment should be used when working at high level?
- (a) safety belt / harness
  - (b) climbing shoes
  - (c) cotton gloves
  - (d) safety goggles
6. The drawing method of the development of a work piece with circular top and square base is :
- (a) parallel lines
  - (b) triangular lines
  - (c) radial lines
  - (d) (a) & (c)
7. Which of the metal below has good properties in ductility, elongation, forging and weldability.
- (a) cast iron
  - (b) wrought iron
  - (c) brass
  - (d) carbon steel

8. The welding method for stainless steel thin sheets should be :
- (a) resistance welding
  - (b) shield metal arc welding
  - (c) MIG
  - (d) TIG
9. What safety precaution should be carried out in welding area ?
- (a) place warning board
  - (b) place warning board & partitions to avoid strong light
  - (c) all peoples in welding area should wear safety goggles
  - (d) store oxygen cylinder
10. Which is the proper treatment to the slag found on the kerf face & bottom after gas cutting ?
- (a) no treatment
  - (b) clean and remove slag
  - (c) painting on the slag
  - (d) both (a) & (c)

11. The circumference of the circular flat bar shall be calculated as :

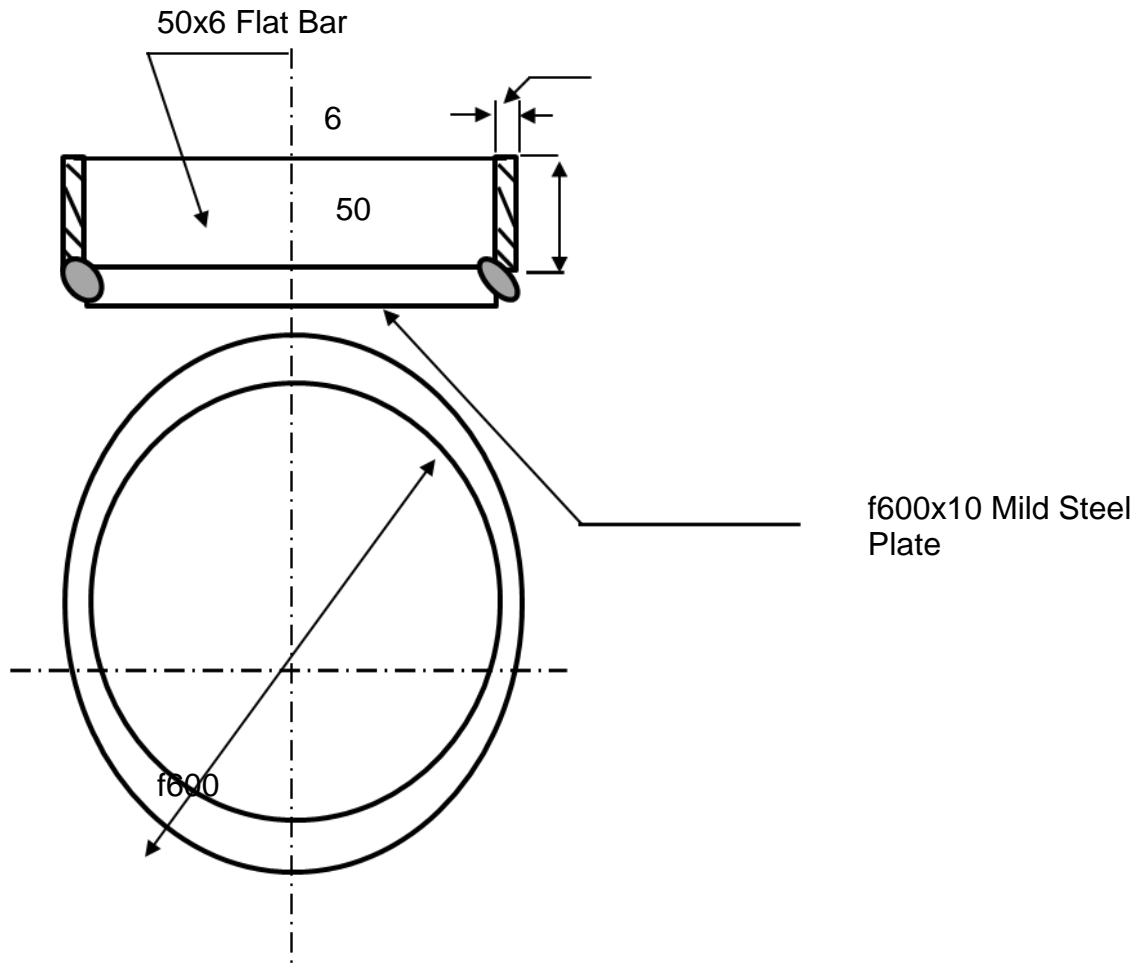

- (a)  $612 \times 3.1416$
- (b)  $600 \times 3.1416$
- (c)  $606 \times 3.1416$
- (d)  $590 \times 3.1416$

12. The classification of steel hammer is :

- (a) by the size of the head
- (b) by the weight of the head
- (c) by the length of the handle
- (d) by the material of the handle

13. Referring to the following figure, which one is the best shape for a 25mm thick butt weld joint ?

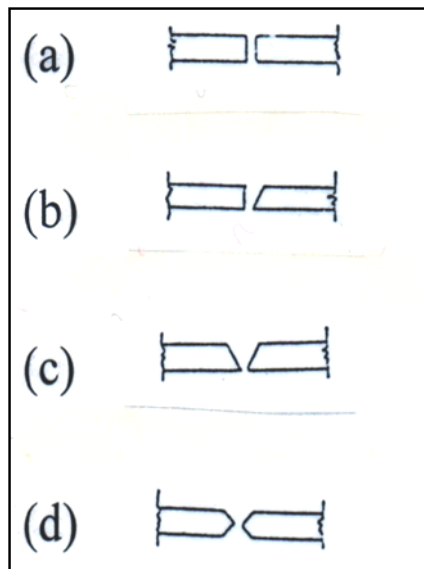

- (a)
- (b)
- (c)
- (d)

14. Which of the follow is a proper handling method to a acetylene gas cylinder during use, transportation and storage :

- (a) kept upright
- (b) kept horizontal
- (c) kept inclined
- (d) roll the gas hose on the cylinder

15. Identify the development which corresponds to the plan & elevation.

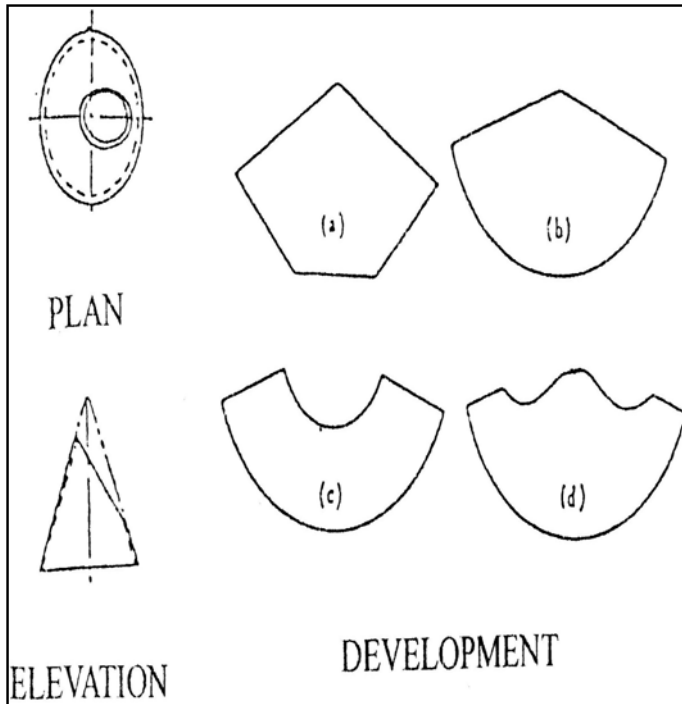

- (a)
- (b)
- (c)
- (d)

16. Which of the following metals can be cut by oxygen-acetylene ?

- (a) copper
- (b) aluminium
- (c) stainless steel
- (d) mild steel



17. The proper working procedure for the fabrication of a cat ladder shall be :
- A Install the cat ladder fixedly
  - B Mark out the position of holes according to the drawing
  - C Understand the working site and preparation work
  - D Install the anchor bolts after drilling
- (a) B,C,A,D
- (b) C,B,D,A
- (c) C,B,A,D
- (d) B,C,A,D
18. Which of the following heat treatment will raise the hardness, strength and abrasiveness of carbon steel.
- (a) annealing
  - (b) quenching
  - (c) normalizing
  - (d) tempering
19. Generally, as strength increases for carbon steels, the ductility:
- (a) increases
  - (b) stays the same
  - (c) decreases
  - (d) is not related to strength

20. What tools are used for marking out on metal ?

- (a) dividers
- (b) center punch
- (c) scribe or oddleg calipers
- (d) All of the above