



CONSTRUCTION
INDUSTRY COUNCIL
建造業議會

Construction Plant Mechanic Trade Test Mock Practical Test Paper

此文件關於建造機械技大工工藝測試考題。如有需要索取此文件的中文版本，請致電 2100 9000 與香港建造業工藝測試中心聯絡。

Disclaimer

No part of this material may be reproduced or transmitted in any form or any means without the written permission of the CIC. Whilst reasonable efforts have been made to ensure the accuracy of the information contained in this material, the CIC nevertheless would encourage readers to seek appropriate independent advice from their professional advisers where possible and readers should not treat or rely on this material as a substitute for such professional advice for taking any relevant actions.

Enquiries

Enquiries on this Material may be made to the Hong Kong Construction Industry Trade Testing Centre at:

95, Yue Kwong Road
Aberdeen
Hong Kong

Tel: (852) 2100 9000
Fax: (852) 2100 9090
Email: enquiry@cic.hk
Website: www.cic.hk

© 2018 Construction Industry Council.

Trade Test Paper

Trade : Construction Plant Mechanic

Grade : Craftsman

Test Contents : Part A : Compulsory Items

Duration : 4½ hours

Complete the following (7) items at the designated location:

	<u>Marks</u>
1. Refer to the attached drawing, mark, file and saw a 5-mm thick m.s. plate. Plate to form the required triangular shape.	5
2. Refer to the attached drawing, adjust welding current, and carry out fillet weld on the both sides of m.s. plate.	10
3. Set up and check oxy-acetylene cutting device properly, adjust the pressure and cut the work piece according to the two lines. (each 100mm in length)	10
4. Cut Ø20mm GI pipe to required length, thread the cut pipe, and install it to the given coupling.	5
5. Dewater a tank of water, including connection and disconnection (afterwards) water hose by means of gasoline engine water pump.	15

- | | |
|--|----|
| 6. Dismantle and assemble a set of hoist brake, including oiling, brake-disc adjustment and working test. | 15 |
| | |
| 7. Dismantle all parts of a petrol-driven concrete poker vibrator, repair and assemble to working condition. | |

Test Contents : Part B : Selective Items
 Duration : 1½ hours
 B(1) : For building works applications
 B(2) : For civil engineering works applications

Part B(1)

Complete the following (3) items at the designated location:

- | | <u>Marks</u> |
|---|--------------|
| 1. Dismantle such parts of an electric-driven concrete poker vibrator as the connector, couplings and electric parts for repairs; and then carry out megger test and running test after assembly. | 10 |
| | |
| 2. Dismantle and assemble all parts of a high pressure water pump, and carry out the tests of flow direction, flow rate and water pressure. | 15 |
| | |
| 3. Give correct answer to the questions (under separate sheet) about the working procedures and safety practices on erection and dismantling of material hoist on site. | 10 |

Part B(2)

Complete the following (2) items at the designated location: 20

1. Inspect and adjust the clearance of the inlet and exhaust valves of a 4-stroke internal combustion diesel engine, set the first cylinder to the explosion position, and carry out running test after assembly.

15

The running test should be completed within 3 times. (maximum 20 seconds per time), or this item would have no score.

2. Adjust a hydraulic cylinder to the required pressure, and then replace an oil seal.

Duration : 6 hours (excluding lunch time)

Notes : (1) Candidate will be marked as fail if he does not carry out safety precautions during the test;
(2) The test paper consists of 4 pages. Total score is 100 as 65 is assigned on Part A and 35 on Part B. Passing mark is 60.

Trade Test for Construction Plant Mechanic

Works Drawing

Figure (1):

Mark, saw and file up a 5-mm thick m.s. plate into the triangular shape as shown below :

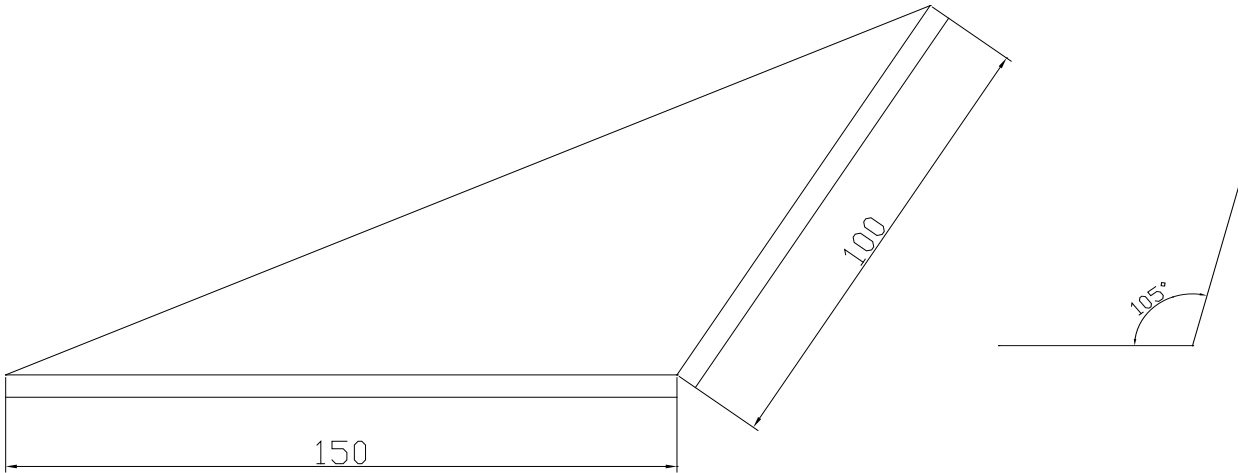
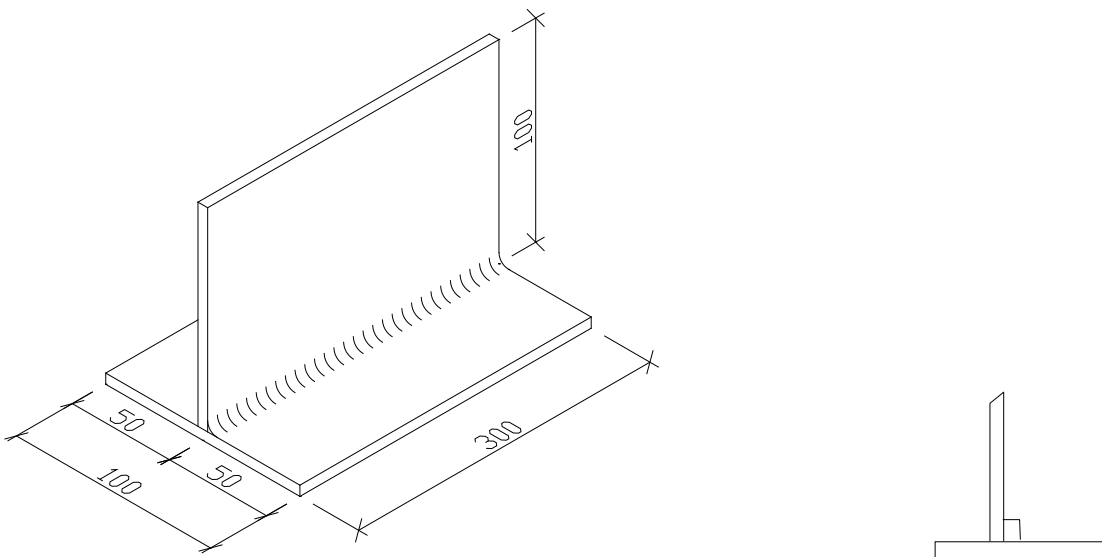

Figure (2):

Fillet weld on the both sides of m.s. plate



Drawing is not to scale All
Dimensions are in mm

Figure (3):

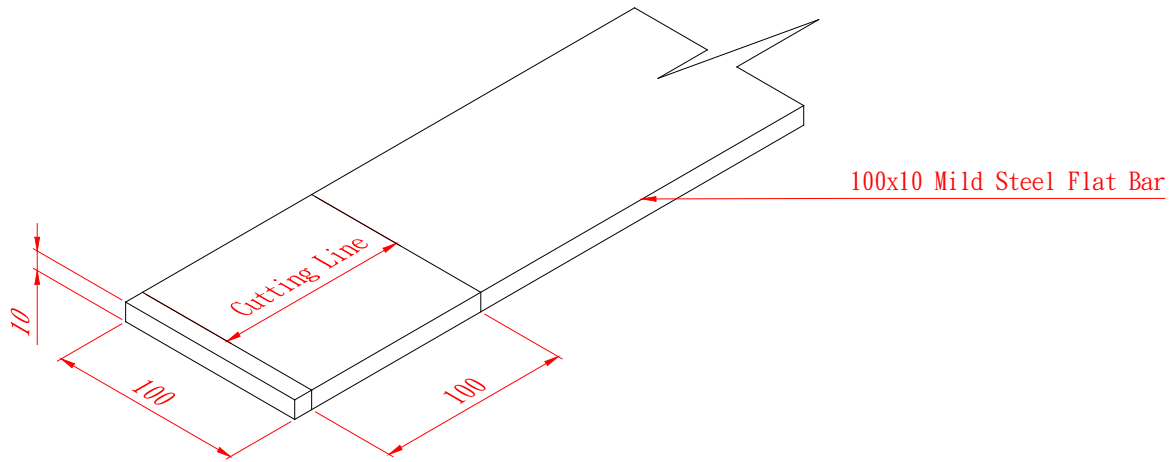

Specifications & Requirements

1. Cut the work piece along the lines drawn on the plate
2. Candidate is required to work on floor.
3. Tolerance of kerf's straightness shall not exceed 3mm.
4. Width of kerf shall not exceed 4mm.
5. Perpendicular of kerf shall not exceed 2.5mm.
6. The slag attached on the bottom of kerf shall be removed.

Figure (4):

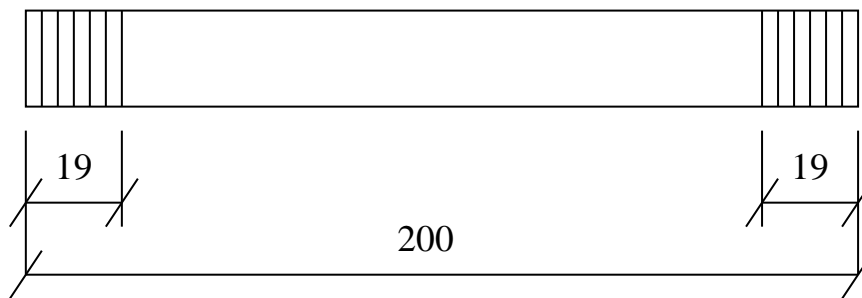

Drawing is not to scale All
Dimensions are in mm

Notes to Candidates :

1. Candidates should read the test papers carefully and ask the invigilator for any queries.
2. Candidates should study the drawings and specifications attached to test papers, if any, before the test begins.
3. Candidates should carry out the test according to test papers, working drawings and specifications provided.
4. Candidates shall bring their own safety shoes, other safety equipment will be provided by trade testing centre. Candidates must take all necessary safety precautions to ensure work safety.
5. All tools and materials required by the test will be provided by trade testing centre, candidates should check and ensure their adequacy and quality. Candidates shall use the tools and materials properly based on trade practice. All the tools must be returned to trade testing centre after the test. The candidates may ask the invigilator for any problems.
6. Candidates are required to handle and move the tools and materials for use in the test, and to carry out associated works.
7. Invigilator will take record photos periodically during the test.
8. Candidates are not allowed to take any photo or video with cameras or mobile phones.
9. Candidates are not allowed to use their mobile phones during the trade tests, except for emergency situation.
10. The marking scheme is based on the following criteria :
 - a) Understanding of drawing and specification
 - b) Preparation works before commencement of test

- c) Working procedures
- d) Accuracy and quality of works
- e) Progress of works
- f) Proper handling and use of materials
- g) Proper use of tools and equipment
- h) Safety precautions
- i) Considerate of other trades
- j) Housekeeping after completion of test

11. All candidates must stop when time is up.
12. Candidates are required to return the test paper to invigilator after the test.
13. Offering bribe to invigilator is an offence in law and trade testing centre will report to the ICAC for any such case.

In the event that the candidate fails to take any necessary safety precautions and / or works in any dangerous situations, he / she will be assessed failed