



DfMA MiMEP Tradeshow 2021

Keynote Speech

Sharing Journey of DfMA MiMEP Development

Ir Gilbert TSANG

Executive Director – Building, E&M, Interiors, China
Gammon Construction Limited



Journal of HKIE – Jan 2021

Modular Integrated Construction

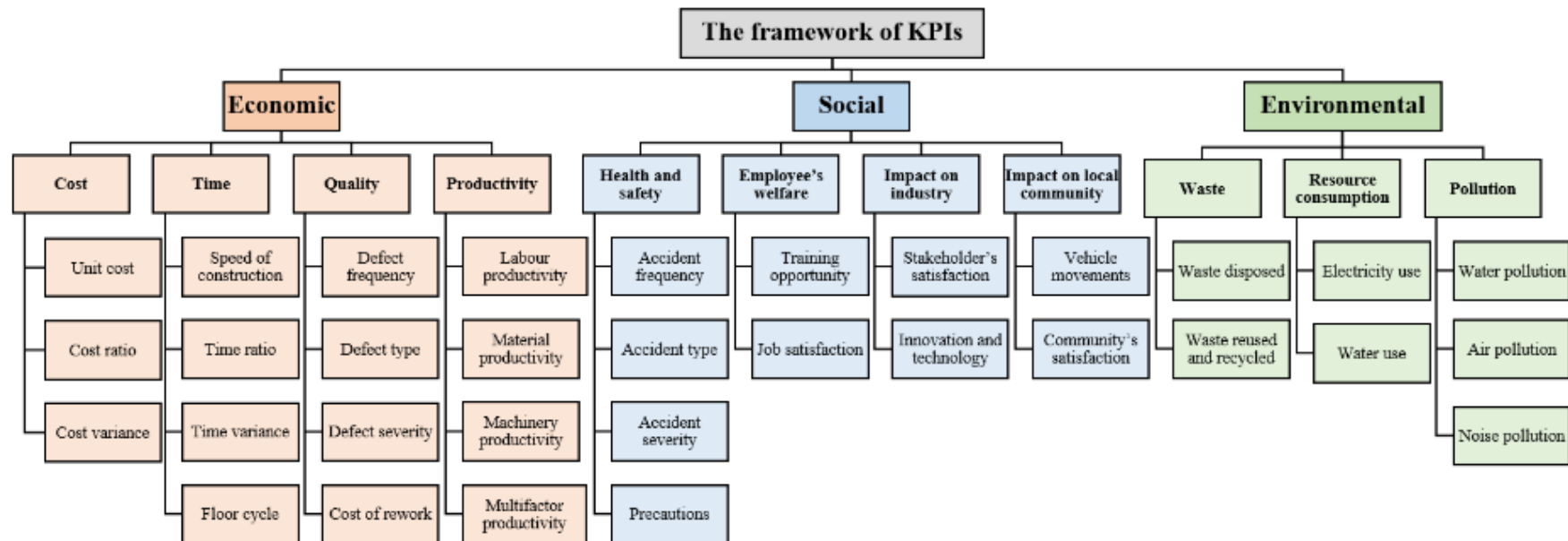

Installation of Ventilation Fan & Silencer (heavy ductwork)

BIM use to improve safe planning of logistic for delivery, installation and future maintenance of tunnel ventilation fans.

1980 ~ 2005
Tunnel Ventilation Ductwork



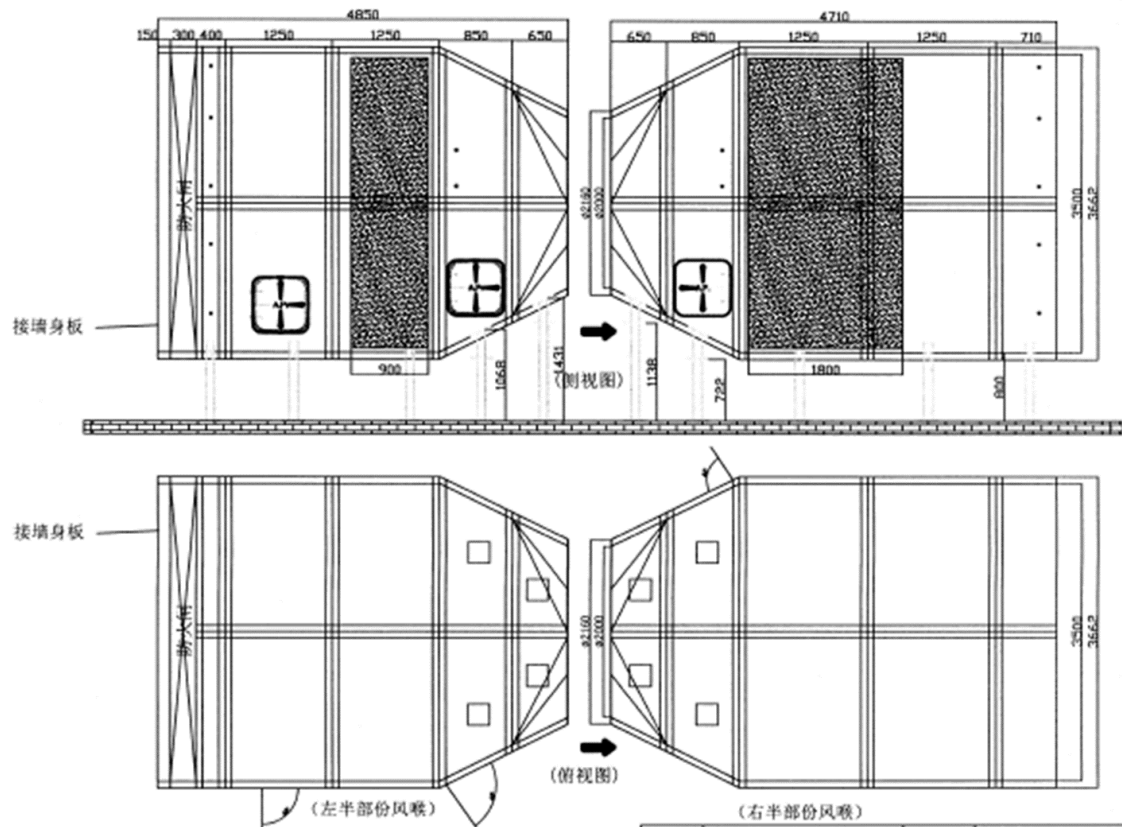

备注

所有预埋件的规格为14x25mm扁钢(镀锌处理),由预埋板中的间距扩大200mm

技术标准及要求

位置	材料规格	材质	用材厚度	连接方式	连接要求	孔距允许公差
D1-预埋板内预埋	扁钢 240x30x4	Q235	6mm	3C4#不锈钢螺栓连接	配2螺母、垫圈、平垫、垫片	<300mm
D1-预埋板内预埋	扁钢 300x30x4	Q235	6mm	3C4#不锈钢螺栓连接	配2螺母、垫圈、平垫、垫片	<300mm
D1-预埋板内预埋	扁钢 350x4x100	Q235	6mm	3C4#不锈钢螺栓连接	配2螺母、垫圈、平垫、垫片	<300mm
D1-预埋板内预埋	扁钢 410x4x100	Q235	6mm	3C4#不锈钢螺栓连接	配2螺母、垫圈、平垫、垫片	<300mm
D1-预埋板内预埋	扁钢 465x4x104	Q235	6mm	3C4#不锈钢螺栓连接	配2螺母、垫圈、平垫、垫片	<300mm

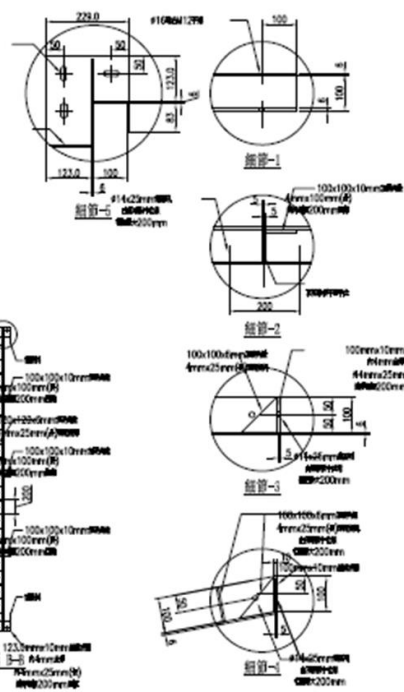
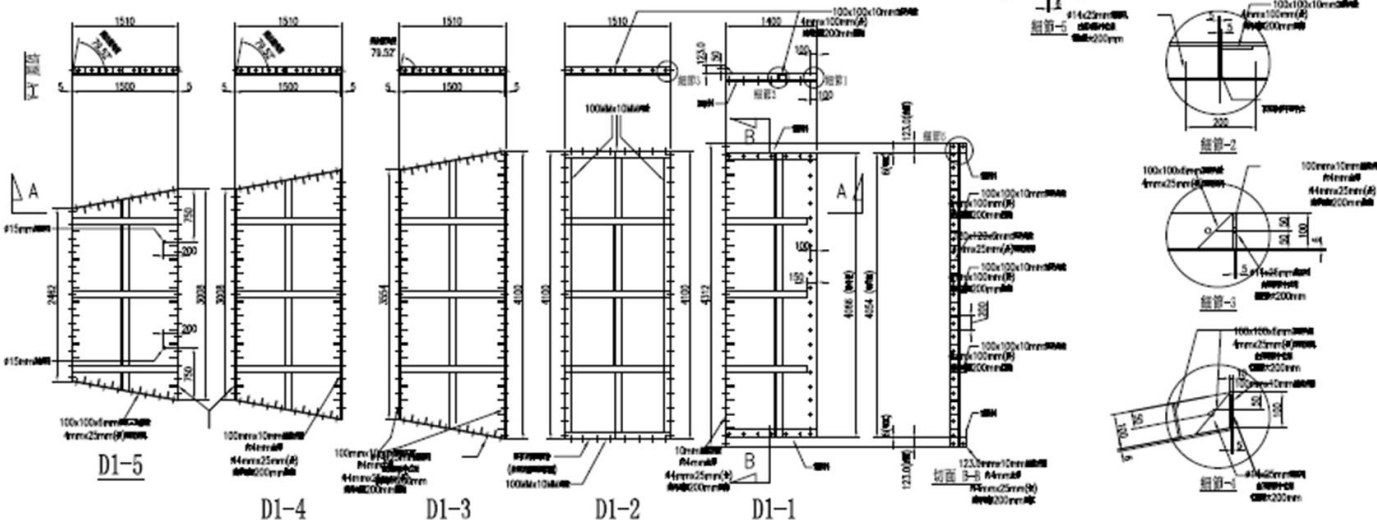
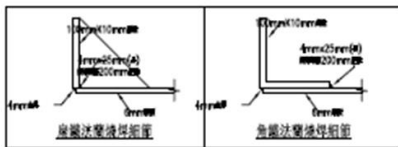

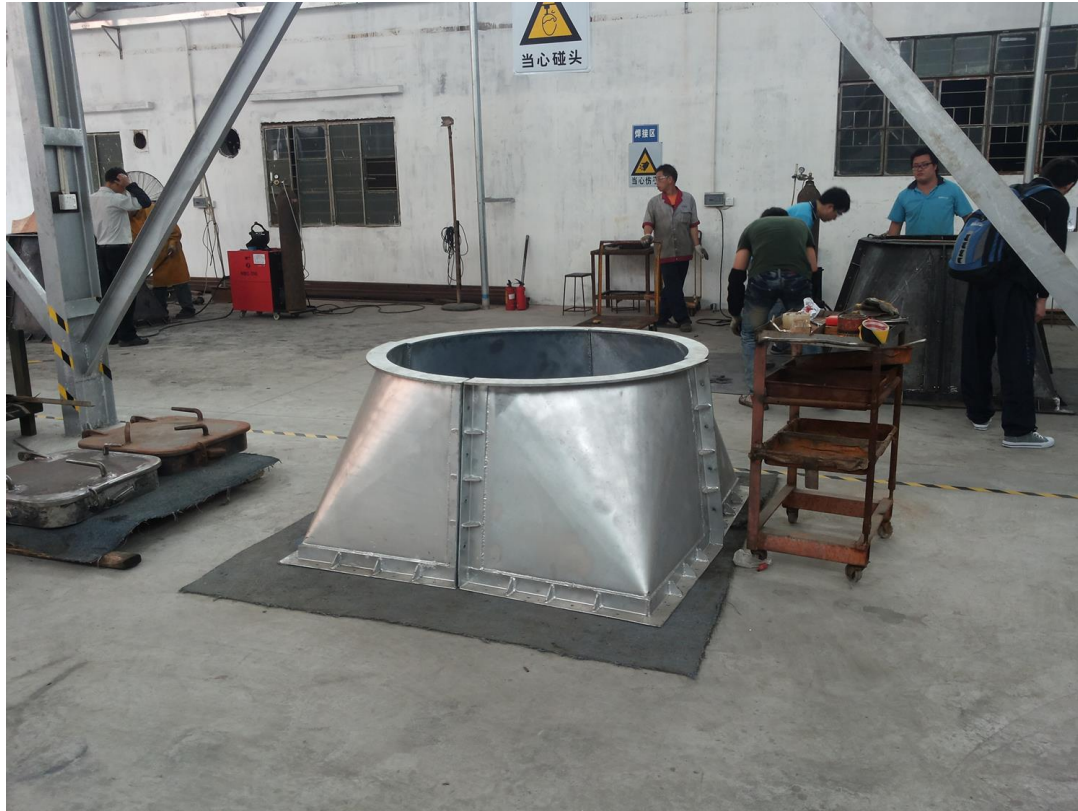





















Our DfMA Journey



<p>2009 - The One</p> <ul style="list-style-type: none"> • Riser Modules • Header Modules • Ductwork Modules  	<p>2011 - Hing Kong Jockey Club</p> <ul style="list-style-type: none"> • Riser Modules • Header Modules • Ductwork Modules  	<p>2013 - China Mobile Data Centre</p> <ul style="list-style-type: none"> • Riser Modules • Header Modules • Containment Module • Hot Work Free Plant Room  	<p>2015 - The Murray Building</p> <ul style="list-style-type: none"> • Riser Modules • Header Modules • FCU Modules  	<p>2015 - Global Switch Data Centre</p> <ul style="list-style-type: none"> • Riser Modules • Header Modules • Containment Module • Pipework Modules • Plantroom Modules • Modular Wiring • FS Pre-action Valve Module  	<p>2019 - L2 Lyric Theatre & AMC</p> <ul style="list-style-type: none"> • Riser Modules • Header Modules • Ductwork Modules • Multi-service Modules • Plantroom Modules • Modular Wiring  
---	---	--	--	--	--



<p>2010 - Tamar & Hysan Place</p> <ul style="list-style-type: none"> • Riser Modules • Header Modules • Ductwork Modules  	<p>2012 - CX Cargo</p> <ul style="list-style-type: none"> • Fan Modules • Header Modules • Ductwork Modules  	<p>2014 - Midfield</p> <ul style="list-style-type: none"> • Riser Modules • Header Modules • Valve Set Modules  	<p>2016 - Lam Lee Street</p> <ul style="list-style-type: none"> • Riser Modules • Header Modules • Ductwork Modules  	<p>2018 - Global Switch Ph. 2 & C4 Tunnel</p> <ul style="list-style-type: none"> • Hot work Free MEP Installation • Vertical Pipework Modules • Horizontal Pipework Modules • Containment Modules • Modular Wiring • Roof E&M Modules  	<p>2020 - Penny's Bay, HKIA T2E, APM, KCR</p> <ul style="list-style-type: none"> • MiC Quarantine Units • MiC Plant Room • Riser Modules • Header Modules • Ductwork Modules • Multi-service Modules • Plantroom Modules • Modular Wiring  
---	--	---	--	---	---



Modularization in BIM Design approach for I-SQ & TheOne (2008 to 2010) = DfMA

Precise assemble construction detail drawing in the design stage

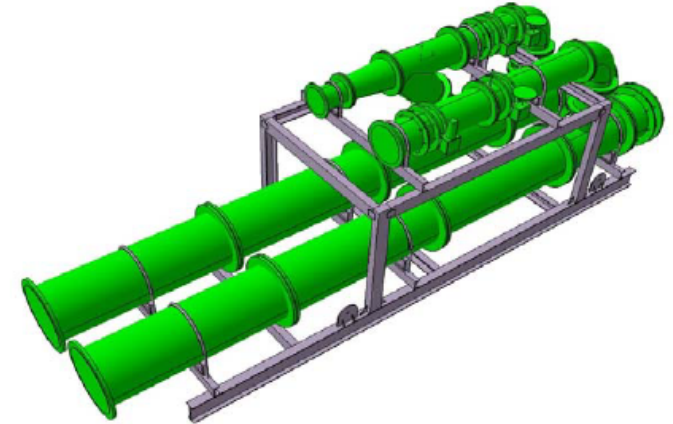
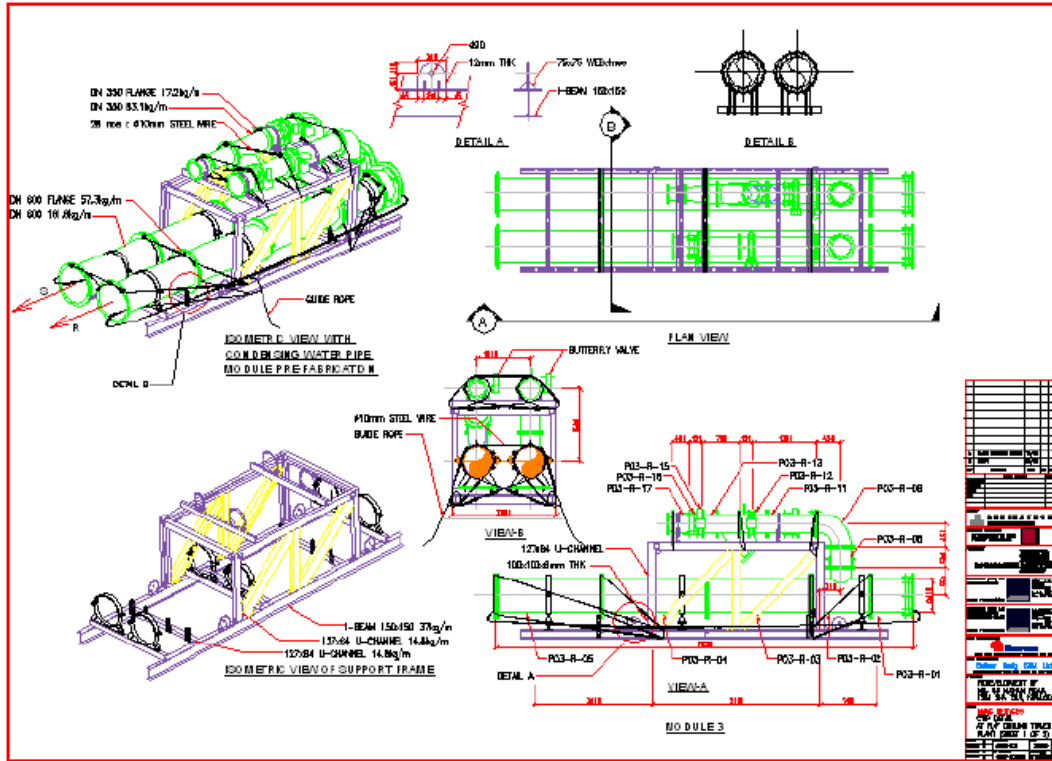

I-Square D.I. pipe module

Modularization in BIM Design approach for I-SQ & TheOne (2008 to 2010) = D f M A

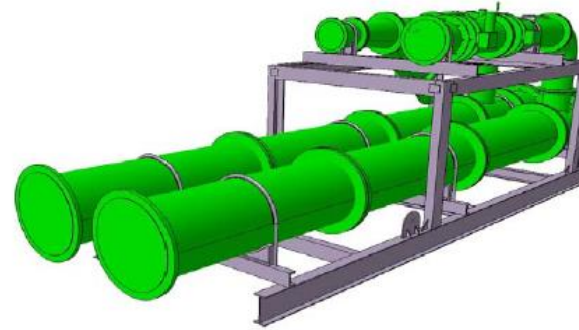

I-Square D.I. pipe module

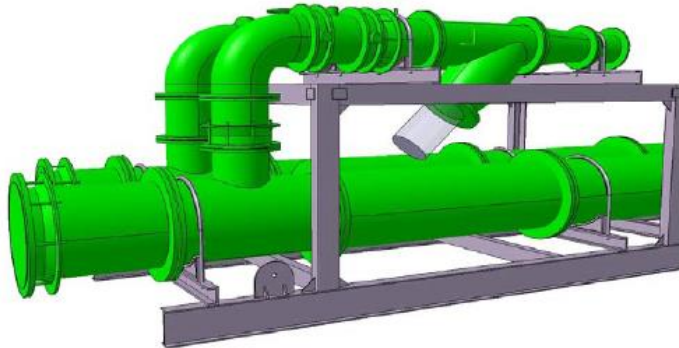

Modularization in BIM Design approach for I-SQ & TheOne (2008 to 2010) = DfMA

Pipe Module Hoist - Structural Integrity in Logistic

DN	Mass(kg)	(x, y)	Density(kg/m ³)	Length(m)	Flange(kg)
350 M1	342.5	(1000, 800)	83.1	3.5	51.6
FLAME M2	717.8	(1000, 1120)			
600 M3	1683.6	(1000, 2022)	181.5	8	229.2
CG		(1000, 1055)			

Detail structural design calculation for the integrity of the module pipework in system operation and uplift hoisting are both considered in the design stage

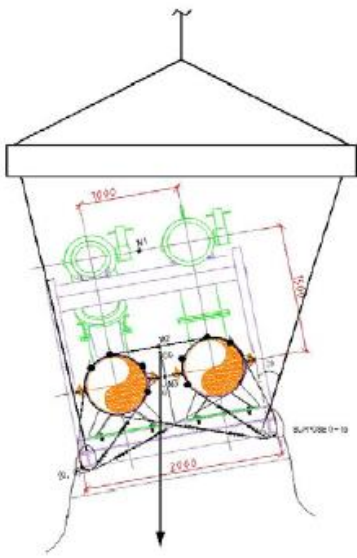

LIFTING EYE AT BASE
= TURN OVER (RISK)

END VIEW OF UP-LIFTING THE CONDENSING WATER PIPE MODULE

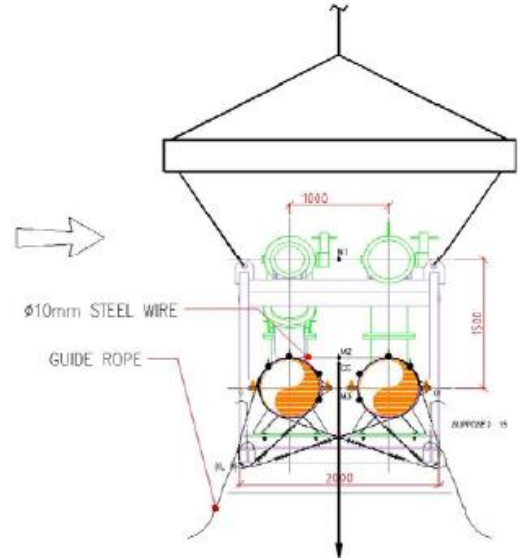

LIFTING EYE AT TOP OF FRAME

I-Square D.I. pipe module hoisting – down lift to roof

NO.	REV.	DATE	BY	CHECKED
1				
2				
3				
4				
5				
6				
7				
8				
9				
10				
11				
12				
13				
14				
15				
16				
17				
18				
19				
20				
21				
22				
23				
24				
25				
26				
27				
28				
29				
30				
31				
32				
33				
34				
35				
36				
37				
38				
39				
40				
41				
42				
43				
44				
45				
46				
47				
48				
49				
50				
51				
52				
53				
54				
55				
56				
57				
58				
59				
60				
61				
62				
63				
64				
65				
66				
67				
68				
69				
70				
71				
72				
73				
74				
75				
76				
77				
78				
79				
80				
81				
82				
83				
84				
85				
86				
87				
88				
89				
90				
91				
92				
93				
94				
95				
96				
97				
98				
99				
100				



Off-site Prefabrication (cont'd)

I-Square D.I. pipe module in MSL (off-site workshop)

Prefabricate:- assemble the pipe fittings, bolt nuts, valves, adaptors onto the steel support framework to made the module and header pipeline;



"Plant in Modularization Design and Construction" (Dec., 2009)



Pipe bracket & base frame assemble

Flange adaptors & tie-rods assemble



Off-site Prefabrication (cont'd)

*Black steel pipe
& flange
welding in off-
site workshop*



The One (Tung Ying) pipe module in MSL (off site workshop)

Prefabricate:- Assemble the pipe fittings, bolt nuts, valves and accessories onto the steel framework to made the module and entire header pipeline ;



"Plant in Modularization Design and Construction" (Dec., 2009)

*Welding Test
for the
Structural
frame*



*Valves &
Actuator
assemble*



MEP Module / MiMEP

Single trade contractor



Combine trade contractor

MEP Module / MiMEP

Local site management

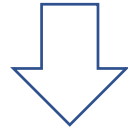

Site management

2018 – Tunnel MEP



DfMA – E&M Module Fabrication

Factory Controlled Environment to enhance Safety, Quality and Productivity



Integrated Digital Project Delivery with STAMP, in-house management tools using QR code to track module and associated data (ID, Design, Progress, Location, Quality, Records,)

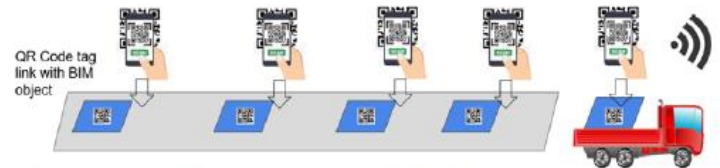

Design → Supply → Fabrication → Quality Control → Delivery





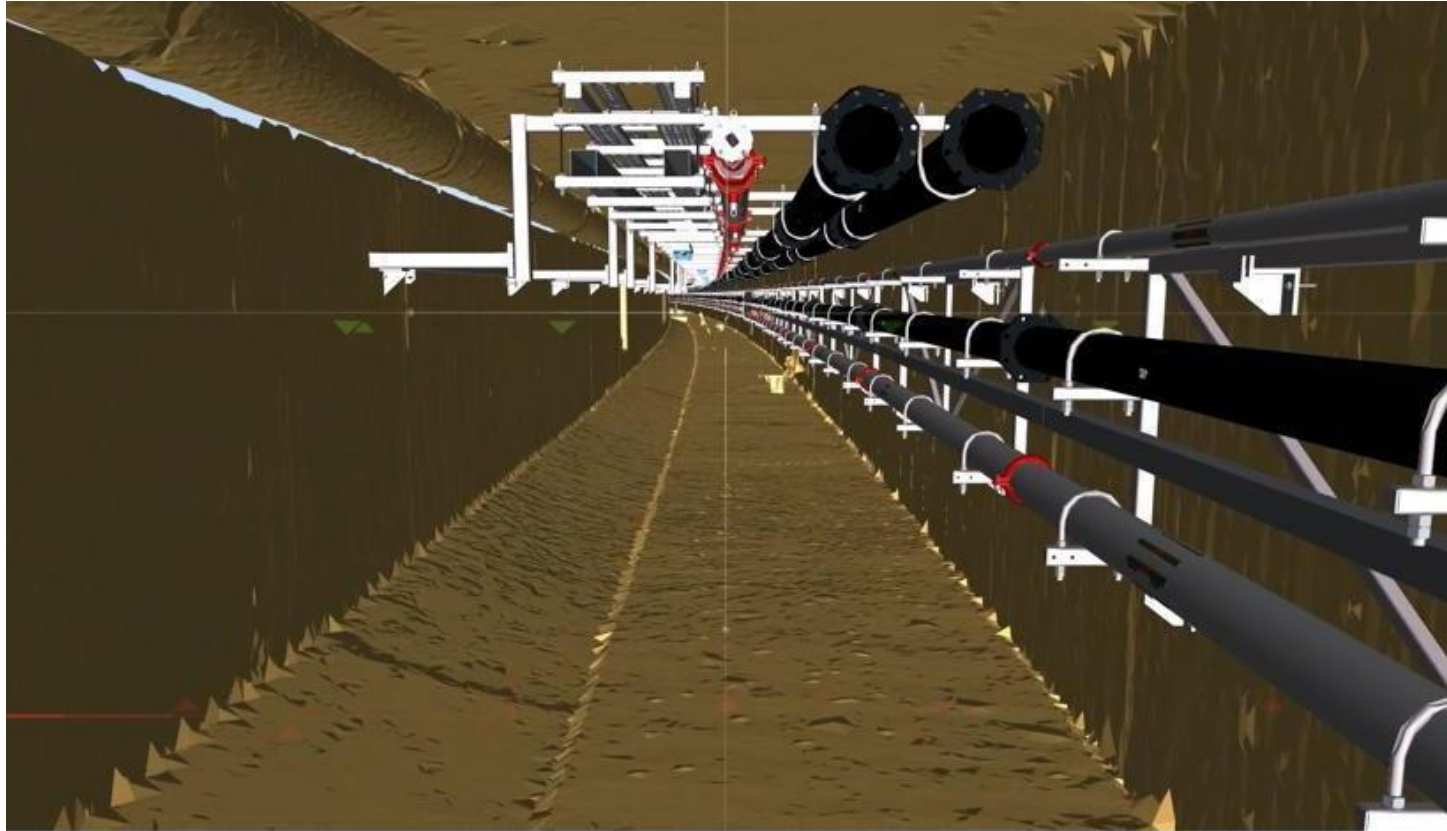

VIRTUAL CONSTRUCTION – DIGITAL TWIN TRIAL



Logistic planning for storage, delivery, handling and installation of E&M Module

Step by step virtual trial of DfMA construction method

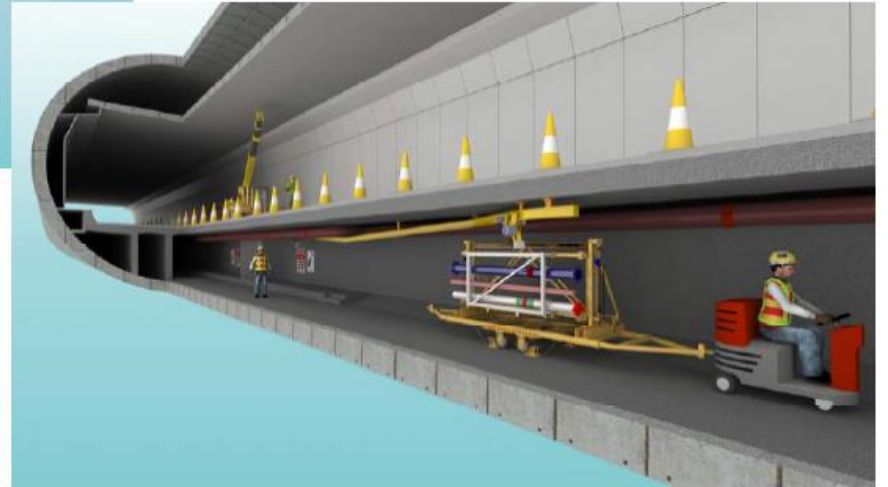

A large yellow arrow pointing to the right, containing the text '2018 Installation and Delivery of DfMA Thermal Tank'.

2018
Installation and Delivery of DfMA
Thermal Tank



DfMA Thermal Tank

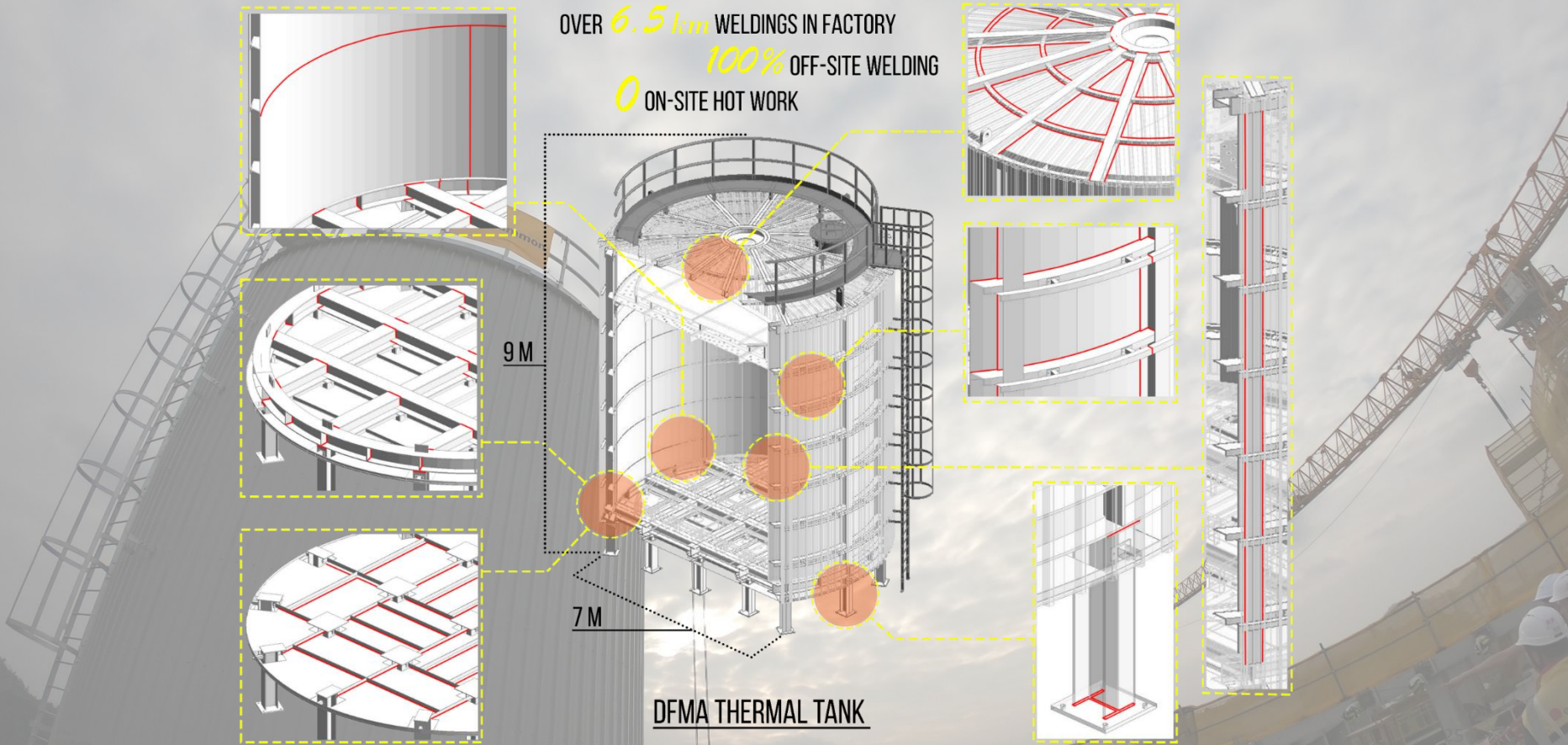

Design Stage

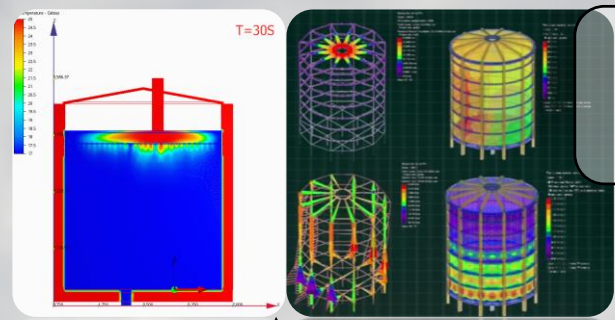

Computation
Fluid Dynamics
Simulation by
BIM

3D Modelling by
BIM

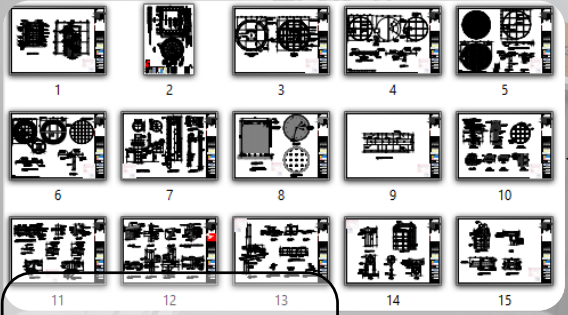

Shop Drawings
Production

BIM

Method
Statement
Planning by BIM



 **Gammon**
THERMAL TANK DELIVERY

Fabrication Off-Site



Structural Steel only



Painting



Cat Ladder with Railing



Structural Steel Only



Coating and Thermal Insulation



External Cladding

Multi-Stage Logistics

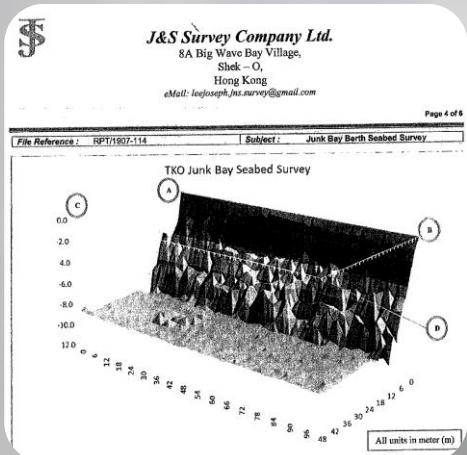

Seabed Survey

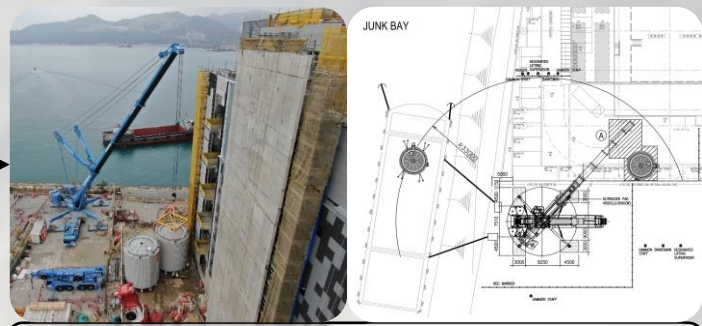

750 Ton Mobile Crane for Hoisting from Sea to Land



500 Ton Mobile Crane for Hoisting from Ground to Level 8 Roof

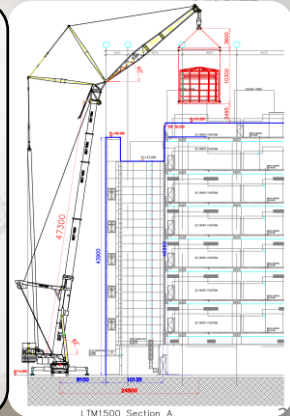

MiMEP in Penny's Bay

2019



MiMEP Module

UG TRENCH PIPE MODULE

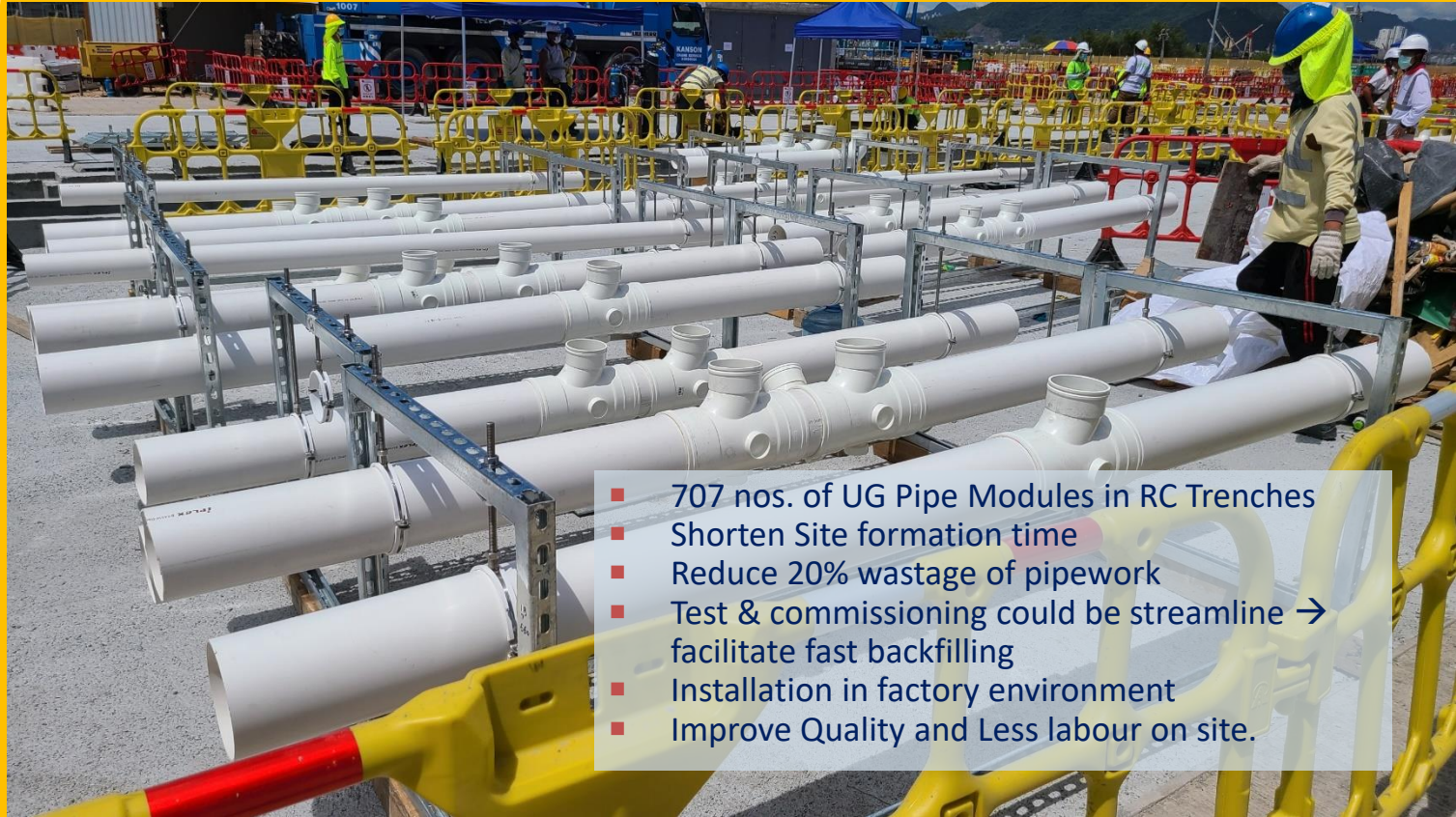

- 707 nos. of UG Pipe Modules in RC Trenches
- Shorten Site formation time
- Reduce 20% wastage of pipework
- Test & commissioning could be streamline → facilitate fast backfilling
- Installation in factory environment
- Improve Quality and Less labour on site.

MiMEP Module

UG Trench Pipe Module at Flying Factory



MiC MiMEP

First MiC Pilot Project



95% MiMEP

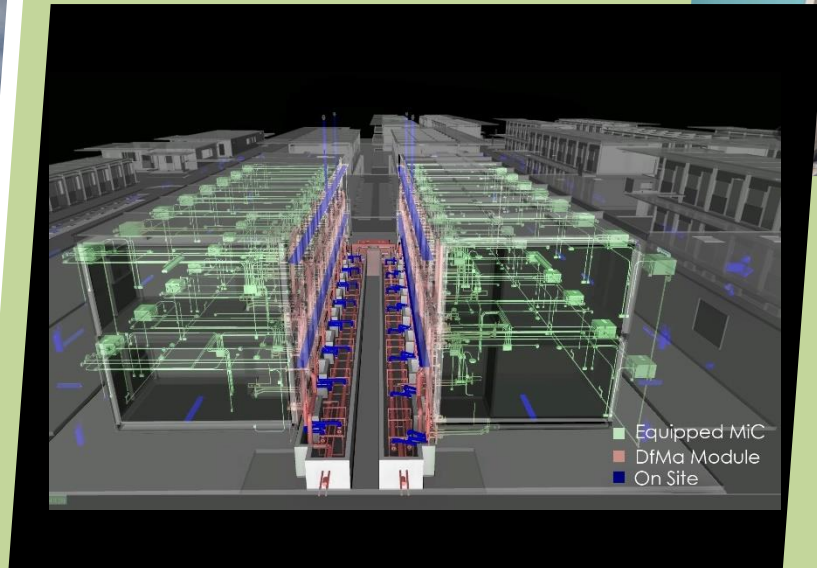

PD Module BIM vs

MiMEP Module

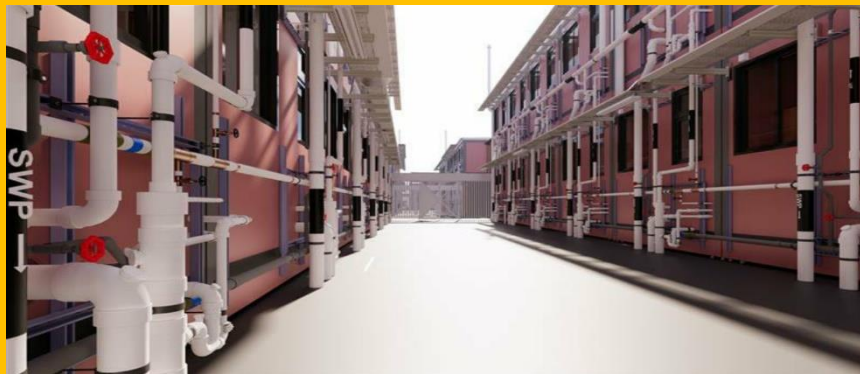

MiMEP Plant Room

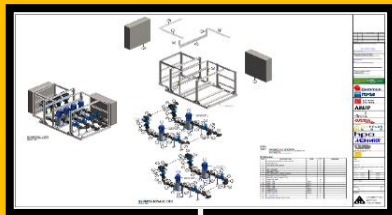

MiMEP Plant Room Design

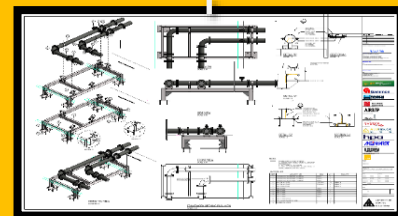
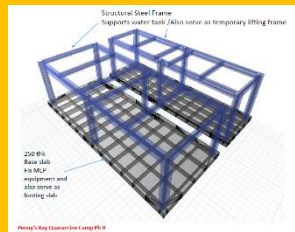
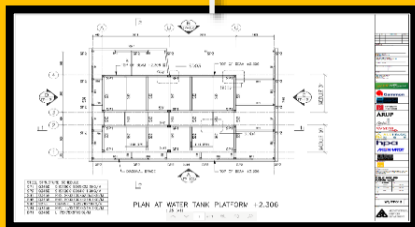
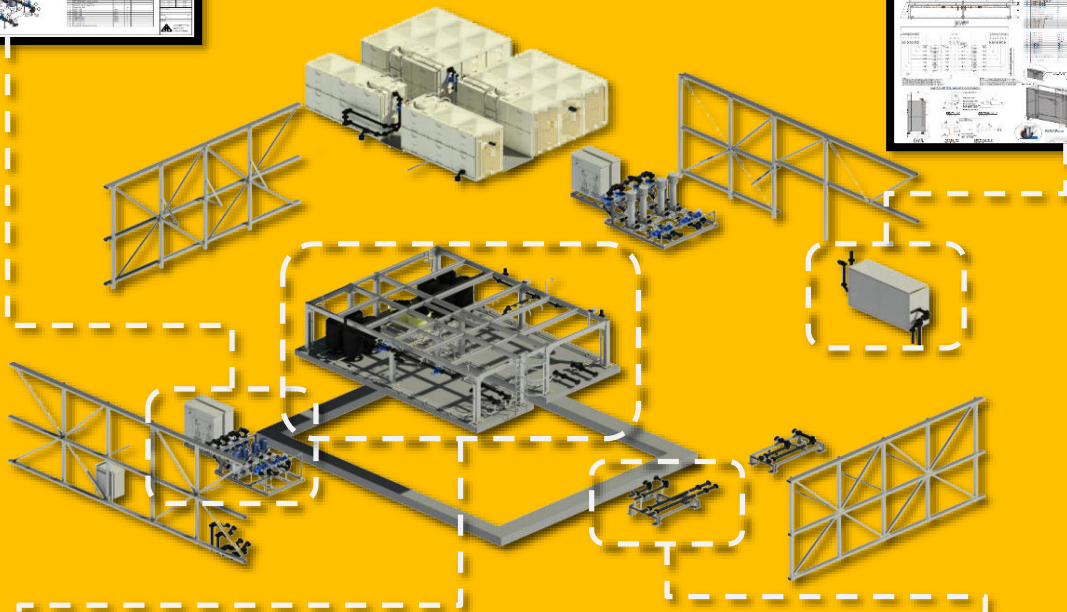
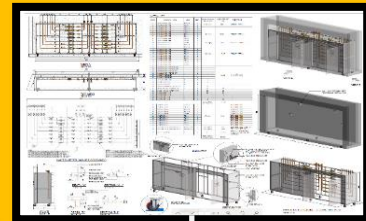

MiMEP Plant Room



MiMEP Plant Room



















2019



Modular Integrated Design

	Design	Off Site Fabrication	Builders Work	MEP Installation	T&C
BIM					
MEP DfMA					
MiC					

Traditional Method

VS

Modular Concept

Off Site Man Power

Site Man Power

Time Duration



Key Summary

Objective

- Social Responsibility in view of current situation
- Support IHEEM as innovation to showcase MiC Capability
- Educational Purpose to the Public



Features

- Follow Center for Disease Control and Prevention Standard
- HEPA Filter with Class H13, 99.7% efficiency
- Larger or equal to 12 Air Changes per Hour
- -15 Pa at Bedroom
- -5 Pa at ANTE Room
- Smoke Test required



Difficulties / Challenge

- Modular Integrated Construction, Plug and Play
- Super Fast Track programme < 1 month
- High Quality Demand, Pressure control



Inside the Ward

Hong Kong Healthcare Engineering
Academy Association

IHEEM
The Institute of Healthcare Engineering and
Estate Management, Hong Kong Branch

Gammon

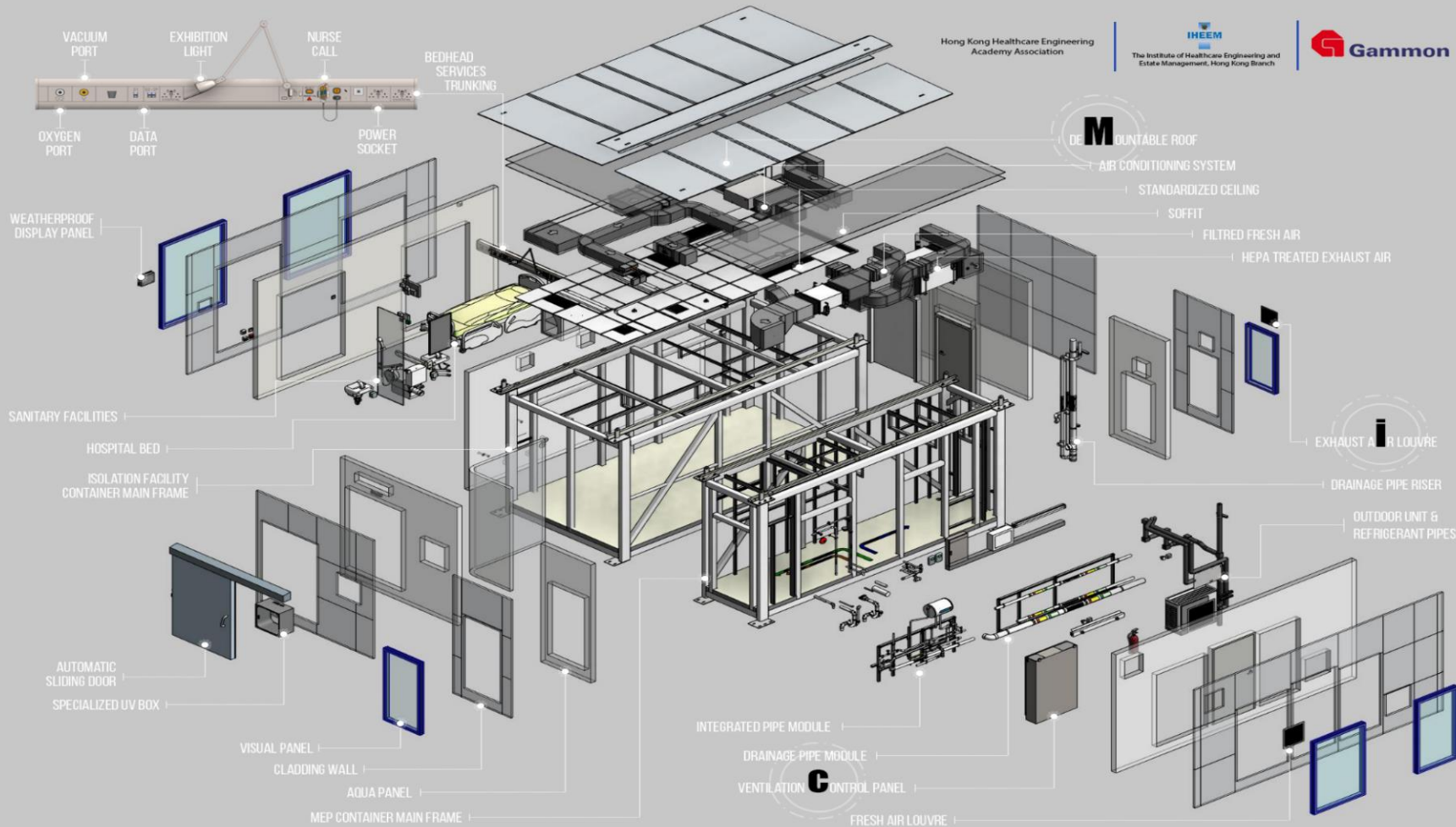

Interfacing – Complexity

- More than 23 Interfacing Points

MEP & Builders Interface

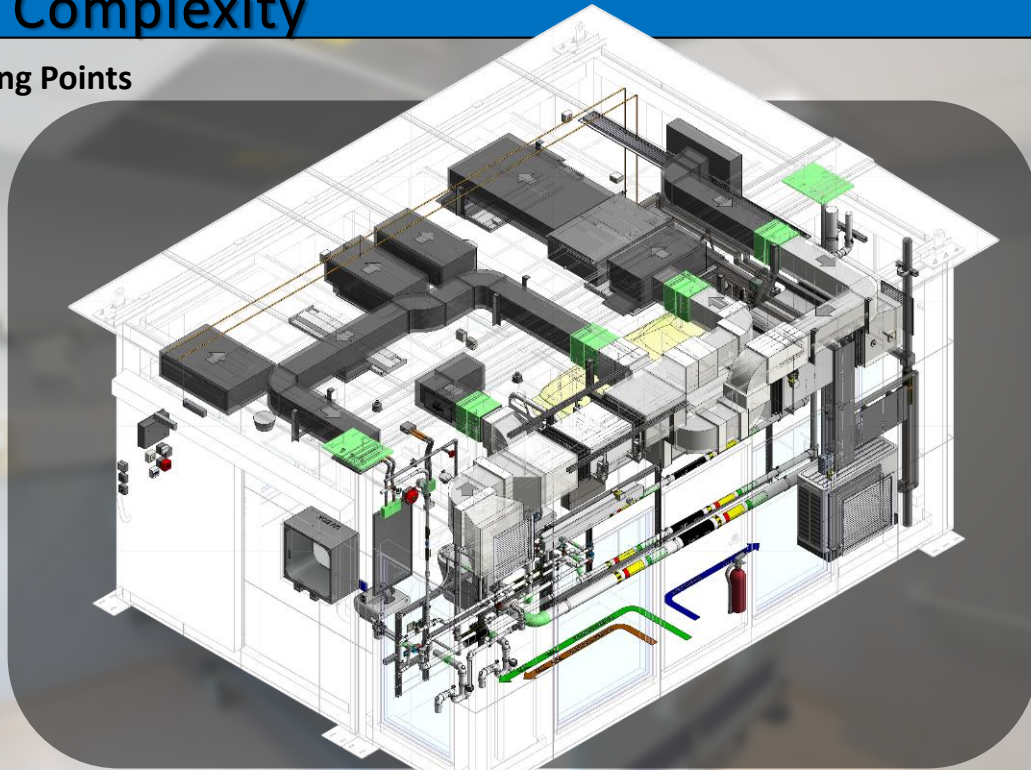

MEP & Fitout Interface



MEP & Façade Interface



Containers Interface



Modular Integrated Design

Modular Integrated Design

- Factory Standard
- Easily Deployable
- Hoist and Go concept
- Flexibility on Design

Hoisting Frame

Demountable Roofing

Modular Design

Visual Panels

Removable Indicators

DfMA on

Modular
Pipework

Demountable Fittings

Demountable MEP Services

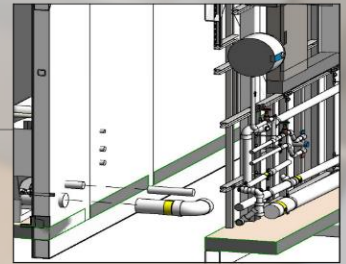
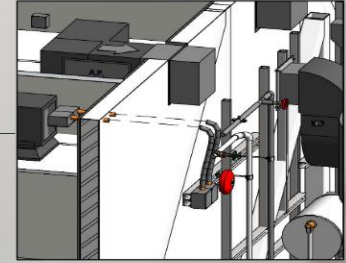
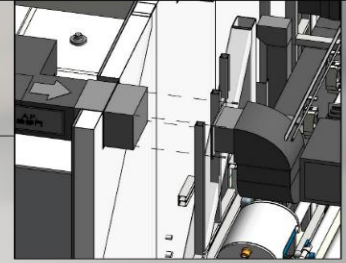
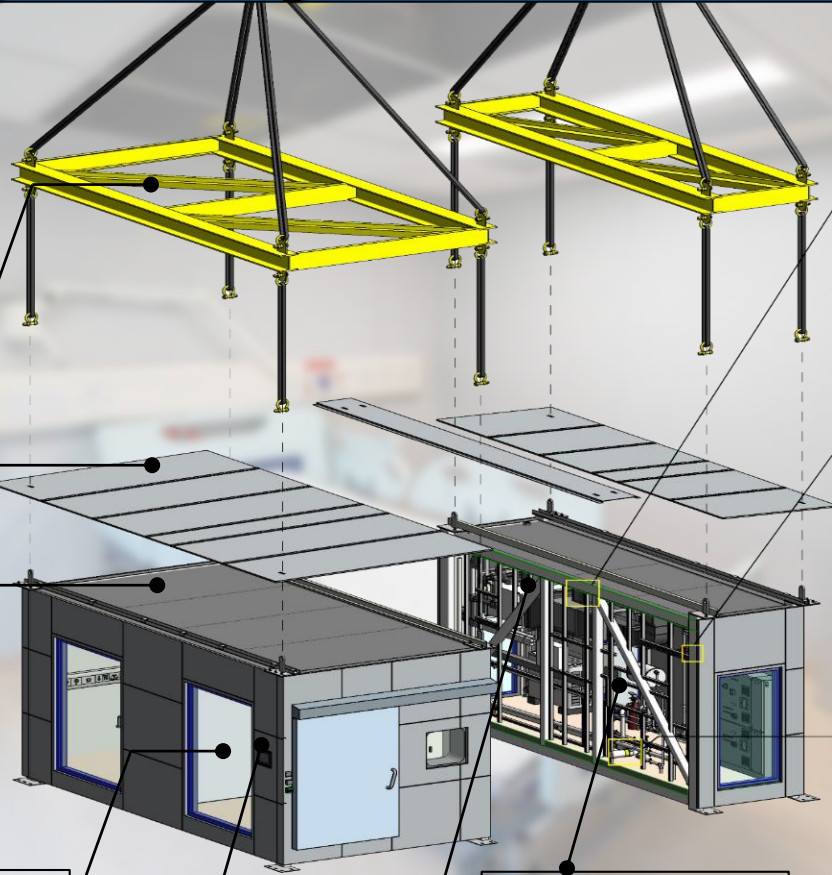

Services Provision by Modular Integrated Design



Modular Integrated Design



Functional Drill with Health Authority



Thank You

建築署
Architectural Services Department

SS JS22 Design & Construction of Temporary Quarantine Facilities (Phase 2) at Penny's Bay

Gammon

HOUSE

RONALD LUI

P&T GROUP

ARUP

SYSTEMA

YOU SAY IT. WE DELIVER!

WE INSTALLED 707 MIC UNITS IN 1 MONTH!

