



CONSTRUCTION  
INDUSTRY COUNCIL  
建造業議會

# Floor Layer (PVC Flooring) Skilled Trade Test Mock Practical Test Paper

此文件關於鋪地板工(塑料地板)工藝測試考題。如有需要索取此文件的中文版本，請致電 2100 9232 與工藝測試中心聯絡。

## **Disclaimer**

*No part of this material may be reproduced or transmitted in any form or any means without the written permission of the CIC. Whilst reasonable efforts have been made to ensure the accuracy of the information contained in this material, the CIC nevertheless would encourage readers to seek appropriate independent advice from their professional advisers where possible and readers should not treat or rely on this material as a substitute for such professional advice for taking any relevant actions.*

## **Enquiries**

Enquiries on this Material may be made to the Trade Test Centre at:

95, Yue Kwong Road  
Aberdeen  
Hong Kong

Tel: (852) 2100 9232  
Fax: (852) 2100 9249  
Email: [enquiry@cic.hk](mailto:enquiry@cic.hk)  
Website: [www.cic.hk](http://www.cic.hk)

## Trade Test Paper

Trade: Floor Layer (PVC Flooring)

Skill Level: Skilled Worker

Question: Complete the following items according to the “Floor Layer (PVC Flooring) Trade Test Shop Drawing” at the specified location (all joints must be tight, the gluing process must also comply with the requirements of the construction specifications of the trade):

1. Fabricate a 1500mm x 1335mm PVC strip flooring (straight forward with colour separation);  
Appropriately mix the materials provided at the venue and make up the floor slab; lay PVC straight-grain flooring, separate colour according to job lines and skirting.
2. Fabricate a 1500mm x 1365mm vinyl sheet flooring;  
Appropriately mix the materials provided at the venue and make up the floor slab; lay vinyl sheet flooring, separate colour according to job lines and skirting.
3. Fabricate a staircase board, skirt, tread and nosing with seamless PVC flooring.
4. Lay “guiding path” (指引路膠) on the stair slab.

Test Time: 6 hours (not including lunch hour)

- Notes:
- (1) The candidate must read the “Notes to Candidates” in the Annex before starting;
  - (2) If the candidate did not complete safety measures during the test, he/she will be deemed to have failed the test; and
  - (3) There are 3 pages in the question. All test items will have a full mark of 100 and 60 marks or above will be considered as pass.

**Floor Layer (PVC Flooring) Trade Test Shop Drawing**

"C" vinyl sheet flooring fold up the wall for 100 mm with finishing line

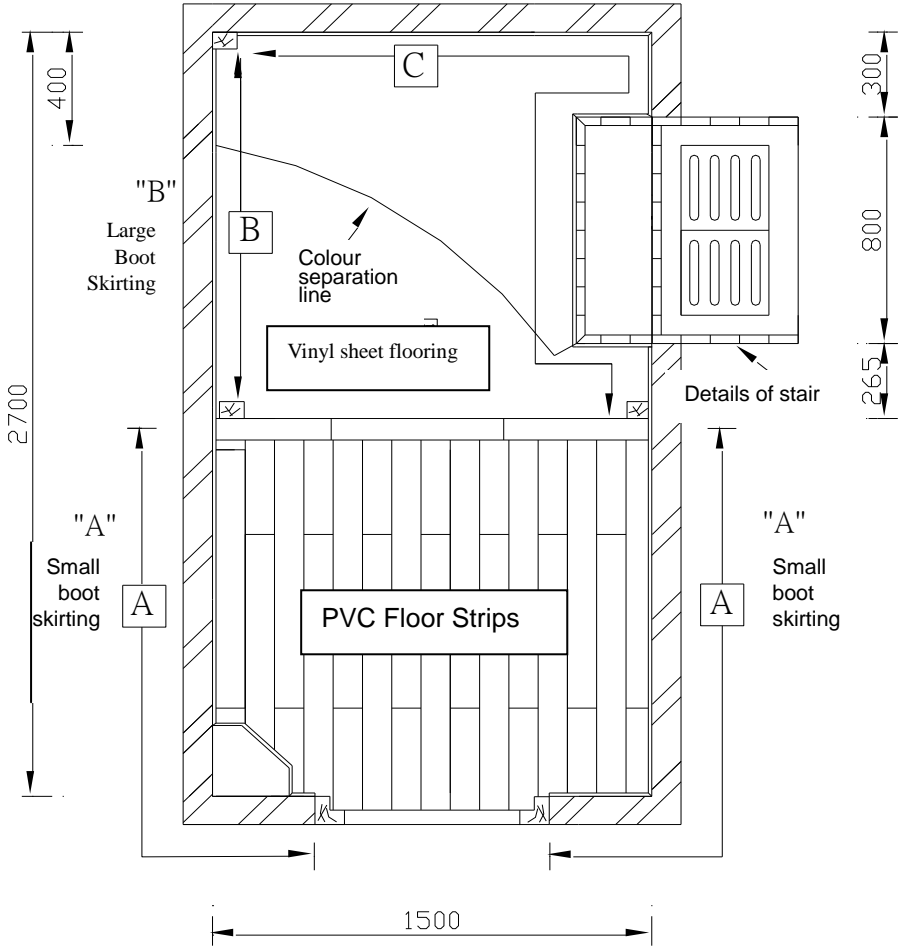

Layout Plan

Drawing not in proportion  
Measurements in mm

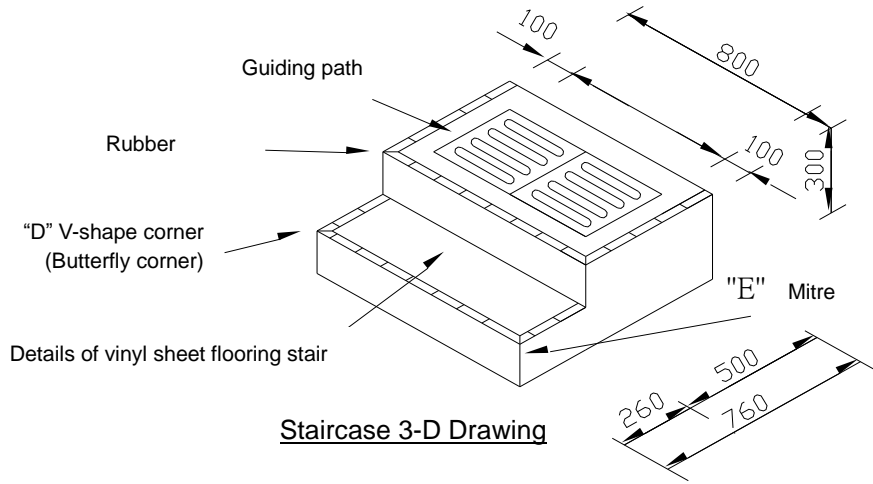
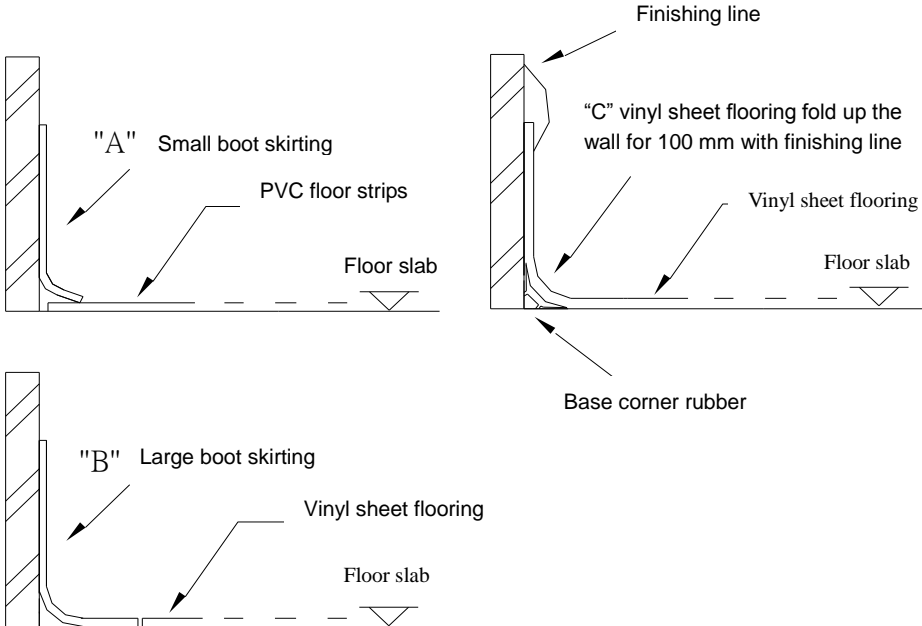

Staircase 3-D Drawing

## Notes to Candidates :

1. Candidates should read the test papers carefully and ask the invigilator for any queries.
2. Candidates should study the drawings and specifications attached to test papers, if any, before the test begins.
3. Candidates should carry out the test according to test papers, working drawings and specifications provided.
4. Candidates shall bring their own safety shoes, other safety equipment will be provided by trade testing centre. Candidates must take all necessary safety precautions to ensure work safety.
5. All tools and materials required by the test will be provided by trade testing centre, candidates should check and ensure their adequacy and quality. Candidates shall use the tools and materials properly based on trade practice. All the tools must be returned to trade testing centre after the test. The candidates may ask the invigilator for any problems.
6. Candidates are required to handle and move the tools and materials for use in the test, and to carry out associated works.
7. Invigilator will take record photos periodically during the test.
8. Candidates are not allowed to take any photo or video with cameras or mobile phones.
9. Candidates are not allowed to use their mobile phones during the trade tests, except for emergency situation.
10. The marking scheme is based on the following criteria :
  - a) Understanding of drawing and specification

- b) Preparation works before commencement of test
- c) Working procedures
- d) Accuracy and quality of works
- e) Progress of works
- f) Proper handling and use of materials
- g) Proper use of tools and equipment
- h) Safety precautions
- i) Considerate of other trades
- h) Housekeeping after completion of test

11. All candidates must stop when time is up.

12. Candidates are required to return the test paper to invigilator after the test.

13. Offering bribe to invigilator is an offence in law and trade testing centre will report to the ICAC for any such case.

**In the event that the candidate fails to take any necessary safety precautions and / or works in any dangerous situations, he / she will be assessed failed**